

APPENDICES

27198

A Glossary of Commonly-Used Computer Terms

This appendix is a short glossary of the commonly-used computer terms that you may encounter while working with the Z-100 Computer.

Acoustic coupler (Modem) – One of the two types of modems: a device you can connect between a standard telephone handset and a computer to communicate with other computers. A modem will translate the normal digital signals of the computer into tones that are transmitted over standard telephone lines and will translate the received tones back into digital signals. By using an acoustic coupler modem, you can use any telephone with a standard handset on a temporary basis and avoid a permanent connection to the telephone lines. See Modem; and Direct-Connect Modem.

Acronym – A word formed from letters found in a name, term, or phrase. For example, FORTRAN is formed from the words FORMula TRANslator,

Address -- The label, name, or number identifying a register, location or unit where data is stored. In most cases, address refers to a location in computer memory.

Algorithm – A defined set of instructions that will lead to the logical conclusion of a task.

Alpha – The letters of the English alphabet.

Alphanumeric -- Letters, numbers, punctuation, and symbols used to represent information or data.

ALU – Arithmetic Logic Unit. This section of the computer performs the arithmetic, logical, and comparative functions of an operation.

ANSI -- American National Standards Institute. This organization publishes standards used by many industries, including the computer industry. Most noted are those standards established for computer languages such as FORTRAN and COBOL.

Application --- A system, problem or task to which a computer has been assigned.

Application program – A program or set of programs designed to accomplish a specific task such as word processing.

Argument – A term used to describe a value in a variable, statement, command, or element of an array or matrix table.

Array – A series of items arranged in a pattern. In computing, this term is used to describe a table with one or more dimensions.

Artificial intelligence – A term used to describe the capability of a machine that can perform functions normally associated with human intelligence: reasoning, creativity, and self-improvement.

ASCII – American Standard Code for Information Interchange. A code used by most computers, including those sold by Zenith Data Systems. € is the industry standard used to transmit information to printers, other computers, and other peripheral devices. The most notable exception is some IBM equipment which uses EBCDIC code. See EBCDIC.

Assemble – A term that means to prepare a machine-usable code from a symbolic code.

Assembler – A computer program used to assemble machine code from symbolic code.

Assembly language – A computer programming language that is machine-oriented and makes use of mnemonics for instructions, operands, and pseudo-operations.

Asynchronous – A mode of operation where the next command is started and stopped by special signals. In communication, the signals are referred to as start and stop bits. See Synchronous.

Backup – A disk copy of data and/or programs that is retained in case the original is damaged or destroyed.

BASIC – Beginner's All-purpose Symbolic Instruction Code. An easily learned programming language consisting largely of English words and terms.

Batch processing – An operation where large amounts of data is processed by a computer with little or no operator supervision. See Interactive processing.

Baud rate – The rate at which information is transmitted serially from a computer. The baud rate is expressed in bits per second.

BCD – Binary Coded Decimal. The method of encoding four bits of computer memory into a binary representation of one decimal digit (number).

Binary – A numbering system with a base of two rather than ten (decimal). See bit.

Bit – 1. A single binary element or digit. 2. The smallest element in computer memory.

Bit density – A measure of the number of bits recorded in a given area.

Block diagram – 1. A graphic representation of the logical flow of operations in a computer program, usually more general than a flowchart. 2. A graphic representation of the electronic configuration of computer hardware and/or peripherals.

Board – A printed circuit board assembly that mounts onto the physical chassis of a computer, peripheral, or other device. Other cards (assemblies) may or may not be "plugged" into this board. See Card.

Boolean algebra – A symbolic system (algebra) named after its developer, George Boole. It is concerned with computer and binary processes and includes logical operators.

Boot – The process of initializing (or loading) a computer operating system. Also referred to as "booting up."

Bootstrap – A program used by a computer to initialize (or load) the operating system of the computer.

Branch – To depart from the sequential flow of an operation as the result of a decision.

Break – The process of interrupting and (usually halting temporarily) a sequence of operations, as in a computer program.

Buffer – An auxiliary storage area for data. Many peripherals have buffers which are used to temporarily store data that the peripheral will use as time permits.

Bug – A term that is widely used to describe the cause of a computer misoperation. The "bug" may be either in the hardware design or in the software (programs) used by the computer.

Bus – A circuit or line used to carry data or power between two or more locations. The S-100 bus, used in the Z-100 Computer, is composed of one hundred separate bus lines.

Byte – A term used to describe a number of consecutive bits. In microcomputers, a byte usually refers to eight bits and is used to represent one ASCII or EBCDIC character.

Cable – An assembly of one or more conductors used to transmit power or data from a source to a destination and, in some cases, vice versa.

Card – A printed circuit board assembly that "plugs" into another card or board and is (usually) held in place by an assembly called a "card cage." See Board.

Centronics-type interface – A parallel printer interface which has become accepted as "quasi-standard" through common usage by a number of manufacturers. See Parallel; Printer; and Interface.

Character – A letter, number, punctuation, operation symbol, or any other single symbol that a computer may read, store, or process.

Checksum – A method of checking the accuracy of characters transmitted, manipulated, or stored. The checksum is the result of the summation of all the digits involved.

Chip – The term applied to an integrated circuit that contains many electronic circuits. A chip is sometimes called an IC or an IC chip. The name occasionally applied to the entire integrated circuit package.

Circuit – A system of electronic elements and connections through which current flows.

Class A – One of two classes established for computers by the Federal Communications Commission regulating the allowable amount of radio frequency interference (RFI) radiation. At one time class A type computers referred to personal computers installed in commercial environments. See Class B.

Class B – One of two classes established for computers by the Federal Communications Commission regulating the allowable amount of radio frequency interference (RFI) radiation. At one time class B type computers referred to personal computers designed for home or residential use. Now all personal computers must meet class B requirements. See Class A.

COBOL – COmmon Business Oriented Language. This common highlevel language is used in a wide number of applications, most notably those dealing with financial transactions.

Code – A method of representing data in some form, as in an ASCII or EBCDIC form.

Command – A code that represents an instruction for the computer.

Communication – The process of transferring information from one point to another.

Compile – The process of producing machine code or pseudo-operational code from a higher level code or language, such as COBOL or FORTRAN.

Compiler – The program that compiles machine code from a higher level code. See Compile.

Composite video – A signal which contains all the elements needed by a video monitor to produce a display. It may be either a color or monochrome signal. See Video; Monitor; RGB video; and CRT.

Computer – A machine capable of accepting information, processing it by following a set of instructions, and supplying the results of this process.

CP/M – Control Program for Microcomputers. This is a disk-based operating system commonly used by many microcomputers. CP/M is a registered trademark of Digital Research, Inc.

CPS – Characters Per Second. This term is sometimes used in relating transmission speed, and is more commonly used in rating a printer's instantaneous printing speed.

CPU – Central Processing Unit. The circuitry that actually processes the information and controls the storage, movement, and manipulation of data. The CPU contains the ALU and a number of registers for this purpose.

Crash – A term that refers to a computer or peripheral failure.

CAT – Cathode-Ray Tube. This term is used interchangeably with display, screen, and video monitor. It refers to the television-like screen in a computer, terminal, or monitor.

Cursor – A character (usually an underline) that is used to indicate a position on the screen.

Cylinder – A term used to describe the tracks in disk systems with multiple read-write heads which can be accessed without mechanical movement of the heads.

Daisy wheel printer – A "hard copy" device that produces images on paper when a "hammer" strikes an arm or projection of the print wheel.

Data – The general term used to describe information that can be processed by a computer. Although the term is plural, it is commonly used in the singular form to denote a group of datum.

Data base – A large file of information that is produced, updated, and manipulated by one or more programs.

Data processing – The action taken by a computer to receive, manipulate, store, and/or print information.

DCE – Data Communications Equipment. The DCE connector is a serial connector designed to be used with communications equipment, generally a modem. See Modem.

Debug – The process of locating and removing any bugs in a computer system; usually as it applies to software.

Decimal – A numbering system with a base of ten consisting of the digits 0 through 9.

Delete – A term that means to remove or eliminate.

Density – A term that refers to the amount of information that can be stored in a given area.

Descenders – That portion of a character which descends below the base line of printed material. Most notably, the lower case g, j, p, q, and y have descenders.

Device – A mechanical or electronic unit, such as a printer, disk drive, terminal, and so on.

Digit – A single element or sign used to convey the idea of quantity, either by itself or with other numbers of its series.

Digital computer – A computer in which numbers are used to express data and instructions.

Direct-connect modem – One of the two types of modems; a device you can connect between a telephone line and a computer to communicate with other computers. A modem will translate the normal digital signals of the computer into tones that are transmitted over standard telephone lines and will translate the received tones back into digital signals. By using a direct-connect modem, you avoid problems associated with high levels of noise and make a more permanent connection to the telephone lines. See Modem; and Acoustic coupler.

Directory – A disk file, listing all of the other files on the disk and pertinent information about each file.

Disk – A thin flexible plastic platter, coated with magnetic material and enclosed in a plastic jacket. It is used to store data and comes in two standard sizes: 5.25-inch and 8-inch in diameter. It is also called a "floppy disk," "flexible disk," or "diskette."

Disk drive – A device used to read data from and write data onto disks. *Diskette* – See Disk.

Disk operating system – See DOS.

Display – The television-like screen used by the computer to present information to the operator.

DOS – Disk Operating System. A program or programs that provide basic utility operations and control of a disk-based computer system.

Dot-matrix printer – A "hard copy" printer that works by forming the printed character through the selection of wires which strike the paper.

Double-density – This term is most often applied to the storage characteristics of disks, and generally refers to the density of the storage of bits on the disk surface on each track. It also refers to the density of the disk tracks, though this is not the common usage.

DTE – Data Terminal Equipment. The DTE connector is a serial connector resigned to be used with a terminal device, which also includes printers. Terminal; and Printer.

EBCDIC – Expanded Binary Coded Decimal Interchange Code. This code, used primarily in IBM equipment, is used to transmit information to peripheral equipment and other computers. It is similar to ASCII code which is the computer industry's standard and is similar. See ASCII.

Edit – A term that means to change data, a program, or a program

EEPROM – Electrically Erasable Programmable Read-Only Memory. Similar to EPROM, and PROM, except that this memory may be selectively red by electronic means and reprogrammed. It is similar in nature to RAM except that special voltages are needed for erasing and programming the memory. An EEPROM is Nonvolatile. See Volatile; RAM; ROM; OM; and EPROM.

EPROM – Erasable Programmable Read-Only Memory. It is similar to PROM, except that this memory is erased by exposing it to a high-intensity ultraviolet light after which it may be reprogrammed. An EPROM is nonvolatile. See Volatile; RAM; ROM; PROM; and EEPROM.

Execute – A term that means to perform a command.

Field – A set of related characters that make up a piece of data such as a field of characters that spell a person's first name.

File – A collection of related records that are treated as a unit. A file may contain data or represent a computer program. See Field and Record.

Firmware – A computer program that is part of the physical makeup of the computer. See Software; and Hardware.

Flowchart – A symbolic representation of the logical flow of operations. It is usually very detailed when it represents a computer program.

Formatting – The process of organizing the surface of a disk to accept files of data and programs.

FORTRAN – FORmula TRANslator. A popular high-level programming language used primarily in scientific applications.

Graphics – This term generally refers to special characters which may be displayed or printed. In other uses, it indicates that the specified device may be able to reproduce any type of display, from photographs to line and bar charts. Often, graphics capabilities are expressed in pixels, points, or dots.

Hard copy – Typewritten or printed characters on paper, produced by a peripheral, such as a printer or plotter.

Hard-sectored – This term applies to disks which have multiple timing holes that mark sector boundaries, as well as the beginning of a track.

Hardware – The physical computer and all of its component parts as well as any peripherals and interconnecting cables. See Firmware; Peripheral; and Software.

Hexadecimal – A numbering system with a base of sixteen, consisting of the digits 0 through 9 and A (10) through F (15). A single byte of data may be represented by two hexadecimal digits.

Hidden file – A file that may be accessed (read) but will not appear on a disk directory. See Disk; Directory; and File.

High-level language – A programming language which uses symbol and command statements that an operator can read. Each statement represents a series of computer machine language instructions. Examples of high-level languages are BASIC, COBOL, and FORTRAN.

Home – This term usually refers to the upper left-hand corner of the display screen, and specifically to the first displayable character location.

I/O – Input/Output. This term refers to the devices which enter and/or store data, and/or the paths through which such data passes. See Port.

IC – Integrated Circuit. See Chip.

Ink jet printer – A "hard copy" device that works by forming printed characters from tightly controlled jets of ink. These printers are often capable of producing multicolored copy and screen images.

Input – 1. Information or data transferred into the computer. 2. The route through which such information passes. 3. The devices which supply a source of input data, such as the keyboard or disk drive.

Instruction – A code that tells a computer to perform a particular operation.

Integer – A whole number.

Interactive processing – An operation where data is processed by a computer under the supervision of an operator, often requiring many keyboard entries. See Batch processing.

Interface – A device that serves as a common boundary between two other devices, such as two computer systems or a computer and peripheral. See RS-232 interface.

Interpreter – A special program that interprets the code in a high-level language for use by the computer. It performs an interpretation each time an instruction is executed; usually this results in slower operation as compared to a compiled computer language. However, the process of testing and debugging an interpreted computer program is much easier and faster. BASIC is an example of an interpreter. However, it is not always found in this form.

Interrupt – A temporary suspension of processing by the computer (and possible override by a high priority routine) caused by input from another part of the computer or a peripheral.

Jump – A departure from the normal sequential line-by-line flow of a program. A jump may be either conditional, based upon the outcome of a test, or unconditional (i.e., absolute).

Justify – To adjust exactly; the perfect alignment of a margin. Text is normally left justified; that is, the left margin is always aligned. A feature of many word processors is right justification; extra spaces between words or increments in spaces between letters are added to perfectly align the right margin.

K – Abbreviation for kilo. 1. A mathematical symbol used to represent 1000. 2. A unit of measurement of capacity in computers that represents the power of 2 closest to 1000 (2^{10} or $1024 = 1K$). See Binary; Kilo; and Kilobyte.

Keyboard – A device used to enter information into a computer. It is made up of two or more keys, often arranged like those of a typewriter and/or calculator.

Keyword – One or two words in a high-level language that define the primary type of operation to be performed.

Kilo – A prefix meaning: (1) 1000 when used in a mathematical expression; or (2) 1024 when used as a unit of measurement in computers. See K; and Kilobyte.

Kilobit – A unit of measurement in computers that equals 1,024 bits. See K; Kilo; and Bit.

Kilobyte – A unit of measurement in computers that equals 1,024 bytes. See K; Kilo; and Byte.

Language – A defined set of characters which, when used alone or in combinations, form a meaningful set of words and symbols. In a computer language, it refers to a set of words and operators and the rules governing their usage. Examples of computer languages are machine language, assembler language, BASIC, COBOL, and FORTRAN.

Load – The process of entering information (data or a program) into a computer, from a keyboard, disk, or other source.

Logical line – Continuous text, instructions, commands, or other material from its beginning to its end, regardless of any breaks imposed upon it by line length limitations of display or printing devices. Logical lines are terminated by the ASCII character CR, which is generated when you press the RETURN key. See Physical line.

M – An abbreviation for mega. 1. A mathematical symbol used to represent 1,000,000. 2. A unit of measurement of capacity in computers that equals 1000K or 1,024,000. See K; Mega; and Megabyte.

Machine language – A programming language consisting only of numbers or symbols that the computer can understand without translation. See Machine Glossary.

Mainframe – 1. The actual central hardware of a computer, containing the Central Processing Unit (CPU). 2. The largest type of computer, usually associated with financial and government institutions and having the ability process very large amounts of data in a batch processing mode.

Maintenance – The process of maintaining hardware and software. With hardware, in addition to corrective repair, this also includes preventive maintenance, or cleaning and adjustment. With software, maintenance refers to updating critical tables and routines (such as the updating of tax tables for income and social security tax deductions in a payroll program).

Matrix – 1. A rectangular array of data usually numeric, subject to mathematical operations or manipulation; any table is a matrix. 2. A rectangular array of elements that form symbols and/or characters in a dot-matrix printer or video display.

Mega – A prefix meaning: (1) 1,000,000 when used in a mathematical expression; or (2) 1,024,000 when used as a unit of measurement in computers. See *M*; and Megabyte.

Megabyte – A unit of measurement in computers that equals 1,024,000 bytes. See *M*; Mega; and Byte.

Memory – That part of a computer that is used to electronically store information (either data or programs). The amount of memory in a microcomputer is often used to imply the size or capability of that computer. See RAM; ROM; PROM; EPROM; and EEPROM.

Microcomputer – A term that (usually) applies to smaller, desktop and personal computer systems. See Minicomputer; and Mainframe.

Minicomputer – A term that applies to medium-sized computer systems. See Microcomputer; and Mainframe.

Mnemonic – A term applying to an abbreviation or acronym that is easy to remember.

Mode – Method of operation. For instance, BASIC has two modes of operation: direct mode and indirect mode.

Modem – MOdulator DEModulator. A device that converts the digital signals from a computer into a form compatible with transmission facilities and vice versa. Most commonly used with telephone communications.

Modulus – The result of modular arithmetic which deals with whole numbers, where the numbers are replaced by their remainders after division by an integer.

Monitor – 1. A control program in a computer. 2. A separate peripheral used to display information; such as a monochrome or color video display.

Monochrome display – A single-color (black and white, black and green, or black and amber) display.

Mouse – A peripheral device with one or two switches that is connected to a computer or terminal and used as an input device. It can serve as a graphics entry device or as a control for (relative) cursor positioning on the screen. See Graphics and Cursor.

Multiprocessing – A term that means doing two or more processes at the same time. This usually applies to computers with more than one CPU.

Multitasking – The ability to do two or more tasks at the same time. This term is often used synonymously with multiprocessing. In computers that have only one active CPU, multitasking is accomplished by "timesharing" the CPU between the tasks. See Timeshare; Multiprocessing; and Multiuser.

Multiuser – The ability to accommodate two or more operators on one computer system at the same time, usually through two or more terminals. See Multi-processing; Multitasking; and Network.

Network – 1. The interconnection of a number of stations by means of a common interface or communications facility, such as a telephone. 2. Two or more computer systems, physically linked together through a common data channel, that are serviced by one or more of the computer systems in that network.

Numeric – Denoting a number or a system of numbers.

OS – Operating System. A program or programs that provide basic utility operations and control of a computer system.

Operation – 1. A defined action. 2. The action specified by a single computer instruction.

Operator – 1. The person who actually manipulates the computer controls, places the disk into the disk drive, removes printer output, etc. 2. A symbol that designates a mathematical operation such as plus (+), minus (-), and so on. 3. A symbol or keyword that designates a logical comparison or operation such as greater than (>), less than (<), NOT, and so on.

Output – The results of computer operations. This may be in the form of displayed or printed information, data stored on (for example) a disk, or data transmitted to another computer.

Parallel – In computers, this refers to information sent as a group, rather than serially. For example, eight bits (or a byte) are transmitted simultaneously over eight channels or wires. See Serial.

Parameter – A specification or value used in an operation or statement.

Parity – Refers to a method used to check the validity of data that is stored, transmitted, or manipulated. The value of a parity bit (which is added to the number of bits which make up one character) will be determined by the desired outcome of the sum of the bits for that character (i.e., to be either an odd or even number).

Peripheral – A device that is connected to the computer for the purpose of supplying input and/or output capability to that computer. A peripheral may or may not be under direct control of the computer; it may be capable of some independent operation (self-test, etc.).

Physical line – Text, instructions, commands, or other material that resides on one line. If the material is broken into two or more lines by line length limitations of a display or printing device, then each line is considered to be one physical line. See Logical line.

Port – The path through which data is transferred into and/or out of the computer or CPU.

Precision – The degree of exactness, usually based on the number of significant digits in a value.

Printer – A device used to produce computer output in the form of written, typed, or printed characters and symbols on paper. The output of a printer is called "hard copy," or a "computer printout."

Problem – A situation where an unknown exists among a given set of knowns. The objective of a program or task in a computer might be the finding of an unknown.

Process – The act of completing or executing an instruction or set of instructions. It may include the capability to compute, assemble, compile, interpret, generate, and so on.

Processor – A computer or its *CPU*. See *CPU*.

Program – A set of computer instructions which, when followed, will result in the solution to a problem or the completion of a task.

Program language – Any one of a number of languages created for a computer. Examples include BASIC, COBOL, FORTRAN, and assembly language.

Programmer – A person who prepares and writes a computer program.

PROM – Programmable Read-Only Memory. Memory which is similar to ROM but which can be programmed (data written to it) by special methods. A PROM is nonvolatile. See Volatile; ROM; EPROM; and EEPROM.

Prompt – A symbol, character, or other sign that indicates that the computer is waiting for some form of operator input. The prompt may request specific data and be made up of text. In other instances, the prompt may simply mean that the computer is finished executing the latest command and is waiting for new instructions in the form of a command.

Pseudo – A prefix meaning imitative.

Queue – A waiting line or list. For example, a list of files waiting to be printed.

RAM – Random Access Memory. Volatile read-write memory in which data may be written to (stored) or read from (retrieved) directly. See Random access; and Volatile.

Random access – The ability to access locations without regard to sequential position; access may be accomplished by going directly to the location. On occasion, this is called "direct access."

Read – The process of obtaining data from some source, such as a disk.

Read/write head – A magnetic recording/playback head similar to those used by tape recorders. The function of the head is to read (playback) and write (record) information on magnetic material such as a disk surface.

Real time clock – A part of the computer that maintains the actual time of day which may be used in a computer program. In many small computers, this is a function of software rather than hardware, and may be subject to timing interrupts caused by certain operations.

Reset – The process of restoring the equipment to its initial state; the state it was in when power was applied and the system turned on.

RGB video – A high-resolution color monitor which utilizes separate red, green, and blue signals rather than a combination, or "composite," of the same. See Monitor; Composite video; CRT; and Display.

ROM – Read-Only Memory. Memory which is similar to RAM, except that data cannot be written to it. Data can be read from it directly, as in the case of RAM, but ROM is nonvolatile; that is, it will retain the information stored in it whether power is applied or not. It is most often used for special programs such as the monitor program in your computer. See Volatile; RAM; PROM; EPROM; and EEPROM.

Routine – A sequence of instructions that carry out a well-defined function. A program may be called a routine, although programs usually contain many routines. If a routine is separated from the main body of the program, it is referred to as a "subroutine."

RS-232 interface – A standardized interface adopted by the Electronic Industries Association (EIA) to ensure uniformity of interfacing signals between computers and peripherals. This capability is built into most computer devices. See Interface.

Search – The systematic examination of data to locate a specific item. Searches are characterized by several different methods including sequential (items are examined in a specific sequence) and binary (ordered data containing the desired item is repeatedly halved until the desired stem is found).

Sector – A portion of a disk track. The location of a particular sector on the track is a matter of timing. In a disk, timing is handled by timing holes. Disks containing only one timing hole are said to be soft-sectored because the timing is handled by software. Disks containing many timing holes are said to be hard-sectored because the timing is handled by hardware. See Track.

Sequential – The order in which things follow one after the other.

Serial – A term that usually refers to the treatment and handling of information. That is, the data is broken down into its component parts, which could be either characters (bytes) or bits. The resulting bytes or bits are then handled (processed, transmitted, or received) in a sequential manner. The term "serial device" refers to the method in which data is passed through or to that device.

Sign – A symbol that indicates whether the value is greater than zero or less than zero. The dash or hyphen sign (-) is used to indicate a negative (less than zero) value. The absence of the dash or a plus sign (+) indicates a value greater than zero (positive).

Single-density – This term is most often applied to the storage characteristics of disks, and generally refers to the density of the storage of bits on the disk surface on each track. It also refers to the density of the disk tracks, though this is not the common usage.

Soft-sectored – This term applies to disks which have a single timing hole that marks the beginning of a track. Sectoring of the track is controlled by software. See Track; and Sector.

Software – A general term that applies to any program (set of instructions) that can be loaded into a computer from any source. See Firmware; and Hardware.

Sort – To arrange (or place in order) data according to a predefined set of rules.

Synchronous – To be controlled by and synchronized (timed) with equally spaced timing signals. See Asynchronous.

Syntax -The rules governing the use of a language.

System – An assembly of components into a whole. A computer system is made up of the computer plus one or more peripherals.

Table – A collection of related data which is in a form suitable for easy reference. See Matrix.

Task – A job, usually performed by following a specific set of instructions to solve a problem.

Telecommunications – The transmission and/or reception of signals by wire, radio, light beam, telephone, or any other electronic means.

Terminal – An input/output device, usually consisting of a keyboard and a display screen. A terminal also may consist of a printer and a keyboard; this is referred to as a "printing terminal." Either type may include a modem (either the acoustic-coupled type or the direct-connect type) for remote operation.

Thermal printer – A "hardcopy" device that works: (1) by forming printed characters by heating tiny elements near or on heat-sensitive paper; or (2) by etching or "burning" printed characters on paper by the use of a low-power laser.

Time share – The process of accomplishing two or more tasks at (apparently) the same time. The computer will process one task at a time, but only a small portion, before switching to the next. Because a computer can process a great amount of data in a very short time, the switching between tasks is usually transparent to human observation except when many tasks are executed at the same time.

Track – The portion of a disk that one read/write head passes over while in a stationary position. Track density is measured in tpi (tracks per inch).

Utility – A program that accomplishes a specific purpose, usually quite commonly needed by a wide range of applications. Most utilities are furnished with a computer system while some, like sort routines, may be sold separately.

Variable – This term applies to a symbol or name that represents an assigned memory location where a value is stored by a program. The maintenance of the variable and its location is handled by the program.

Verify – To examine and substantiate the results of a computer operation.

Volatile – A characteristic of becoming lost or erased when operating power is removed from the hardware. See RAM.

Winchester – A term applied to most forms of high-density, nonremovable rigid disk storage devices.

Word processing – An application, widely used in microcomputers for entering, manipulating, correcting, deleting, formatting, and printing various types of text: correspondence, reports, legal documents, articles, manuscripts, and books. These application programs often include a spelling checker and other aids to the writer: punctuation checker, thesaurus, and indexer.

Write – The process of recording data on some object, such as a display, disk, or paper.

Symbols and Codes

This appendix contains a number of tables: a decimal/octal/hexadecimal ASCII conversion table; three key code tables; and five control code tables.

Table B-1 describes the entire ASCII character set as implemented in the Z-100. The Z-19 graphics characters and foreign characters are not illustrated in the table.

If you want to see the graphics or foreign characters, use the FONT utility of MS-DOS to load the appropriate CHR file from MS-DOS distribution disk #2. The font utility provides you with the means to view and the characters to suit your own needs. Refer to the MS-DOS documentation for complete instructions.

Tables B-2 through B-4 contain the hexadecimal or ASCII codes sent by the keyboard for each key you press (and release) under different conditions. The conditions in Table B-2 are represented by the following: (1) normal or default keyboard operation with no extra keys pressed, (2) either SHIFT key pressed, (3) the CTRL key pressed, (4) both the CTRL and either SHIFT key pressed, (5) the CAPS LOCK key locked down, (6) the keyboard in the event-driven mode when a key is pressed, and (7) the keyboard in the event-driven mode when a key is released.

Tables B-5 through B-9 contain the description of each control code combination that the computer recognizes and the function performed.

Table B-1: The ASCII Character Set

DECIMAL	OCTAL	HEXADECIMAL	ASCII CHARACTER	KEY	CTRL	DESCRIPTION
0	000	00	NUL	...	@	Null, tape feed.
1	001	01	SOH	...	A	Start of heading.
2	002	02	STX	...	B	Start of text.
3	003	03	ETX	...	C	End of text.
4	004	04	EOT	...	D	End of transmission.
5	005	05	ENQ	...	E	[Enquiry] Inquiry.
6	006	06	ACK	...	F	Acknowledge.
7	007	07	BEL	...	G	Rings bell (sounds tone).
8	010	08	BS	BACKSPACE	H	Back space.
9	011	09	HT	TAB	I	Horizontal tab.
10	012	0A	LF	LINE FEED	J	Line feed - advance cursor to next line.
11	013	0B	VT	...	K	Vertical tab (VTAB).
12	014	0C	FF	...	L	Form feed to top of next page.
13	015	0D	CR	RETURN	M	Carriage return to beginning of line.
14	016	0E	SO	...	N	Shift out.
15	017	0F	SI	...	0	Shift in.
16	020	10	DLE	...	P	Data link escape.
17	021	11	DC1	...	Q	Device control 1 - turns transmitter on (XON).
18	022	12	DC2	...	R	Device control 2.
19	023	13	DC3	...	S	Device control 3 - turns transmitter off (XOFF).
20	024	14	DC4	...	T	Device control 4.
21	025	15	NAK	...	U	Negative acknowledge or ERR (error).
22	026	16	SYN	...	V	Synchronous idle (SYNC).
23	027	17	ETB	...	W	End of transmission block.
24	030	18	CAN	...	X	Cancel (CANCL) - cancels current escape sequence.
25	031	19	EM	...	Y	End of medium.
26	032	1A	SUB	...	Z	Substitute.
27	033	1B	ESC	ESC	[Escape.
28	034	1C	FS	...	\	File separator.
29	035	1D	GS	...]	Group separator.
30	036	1E	RS	...	^	Record separator.
31	037	1F	US	...	-	- Unit separator.
32	040	20	SP	space bar	...	Space (space bar).
33	041	21	!	!	...	Exclamation mark.
34	042	22	"	"	...	Quotation (ditto) mark.

Table B-1 (continued): The ASCII Character Set

DECIMAL	OCTAL	HEXADECIMAL	ASCII CHARACTER	KEY	CTRL	DESCRIPTION
35	043	23	#	#	...	Number sign.
36	044	24	\$	\$...	Dollar sign.
37	045	25	%	%	...	Percent sign.
38	046	26	&	&	...	Ampersand.
39	047	27	'	'	...	Acute accent or apostrophe.
40	050	28	((...	Open parenthesis.
41	051	29))	...	Close parenthesis.
42	052	2A	*	*	...	Asterisk.
43	053	2B	+	+	...	Plus sign.
44	054	2C	...	Comma.		
45	055	2D	-	-	...	Hyphen or minus sign.
46	056	2E	...	Period.		
47	057	2F	/	/	...	Slash.
48	060	30	0	0	...	Number 0.
49	061	31	1	1	...	Number 1.
50	062	32	2	2	...	Number 2.
51	063	33	3	3	...	Number 3.
52	064	34	4	4	...	Number 4.
53	065	35	5	5	...	Number 5.
54	066	36	6	6	...	Number 6.
55	067	37	7	7	...	Number 7.
56	070	38	8	8	...	Number 8.
57	071	39	9	9	...	Number 9.
58	072	3A	:	:	...	Colon.
59	073	3B	;	;	...	Semicolon.
60	074	3C	<	<	...	Less than sign.
61	075	3D	=	...	Equal sign.	
62	076	3E	>	>	...	Greater than sign.
63	077	3F	?	?	...	Question mark.
64	100	40	@	@	...	At sign.
65	101	41	A	A	...	Capital letter A.
66	102	42	B	B	...	Capital letter B.
67	103	43	C	C	...	Capital letter C.
68	104	44	D	D	...	Capital letter D.
69	105	45	E	E	...	Capital letter E.
70	106	46	F	F	...	Capital letter F.
71	107	47	G	G	...	Capital letter G.
72	110	48	H	H	...	Capital letter H.
73	111	49	I	I	...	Capital letter I.
74	112	4A	J	J	...	Capital letter J.
75	113	4B	K	K	...	Capital letter K.

Table B-1 (continued): The ASCII Character Set

			ASCII			
DECIMAL	OCTAL	HEXADECIMAL	CHARACTER	KEY	CTRL	DESCRIPTION
76	114	4C	L	L	...	Capital letter L.
77	115	4D	M	M	...	Capital letter M.
78	116	4E	N	N	...	Capital letter N.
79	117	4F	O	O	...	Capital letter O.
80	120	50	P	P	...	Capital letter P.
81	121	51	Q	Q	...	Capital letter Q.
82	122	52	R	R	...	Capital letter R.
83	123	53	S	S	...	Capital letter S.
84	124	54	T	T	...	Capital letter T.
85	125	55	U	U	...	Capital letter U.
86	126	56	V	V	...	Capital letter V.
87	127	57	W	W	...	Capital letter W.
88	130	58	X	X	...	Capital letter X.
89	131	59	Y	Y	...	Capital letter Y.
90	132	5A	Z	Z	...	Capital letter Z.
91	133	5B	[[...	Open brackets.
92	134	5C	\	\	...	Reverse slash.
93	135	5D]]	...	Close brackets.
94	136	5E	...	^	...	Caret.
95	137	5F	_	_	...	Underscore.
96	140	60	`	`	...	Grave accent.
97	141	61	a	a	...	Small letter a.
98	142	62	b	b	...	Small letter b.
99	143	63	c	c	...	Small letter c.
100	144	64	d	d	...	Small letter d.
101	145	65	e	e	...	Small letter e.
102	146	66	f	f	...	Small letter f.
103	147	67	g	g	...	Small letter g.
104	150	68	h	h	...	Small letter h.
105	151	69	i	i	...	Small letter i.
106	152	6A	j	j	...	Small letter j.
107	153	6B	k	k	...	Small letter k.
108	154	6C	l	l	...	Small letter l.
109	155	6D	m	m	...	Small letter m.
110	156	6E	n	n	...	Small letter n.
111	157	6F	o	o	...	Small letter o.
112	160	70	p	p	...	Small letter p.
113	161	71	q	q	...	Small letter q.
114	162	72	r	r	...	Small letter r.
115	163	73	s	s	...	Small letter s.
116	164	74	t	t	...	Small letter t.

Table B-1 (continued): The ASCII Character Set

			ASCII			
DECIMAL	OCTAL	HEXADECIMAL	CHARACTER	KEY	CTRL	DESCRIPTION
117	165	75	u	u	...	Small letter u.
118	166	76	v	v	...	Small letter v.
119	167	77	w	w	...	Small letter w.
120	170	78	x	x	...	Small letter x.
121	171	79	y	y	...	Small letter y.
122	172	7A	z	z	...	Small letter z.
123	173	7B	{	{	...	Left brace.
124	174	7C			...	Vertical bar (broken).
125	175	7D	}	}	...	Right brace.
126	176	7E	...	~	...	Tilde.
127	177	7F	DEL	DELETE	...	Delete (rubout).
128-255	200-377	80-FF	unassigned.

Table B-2: Hexadecimal Key Codes

KEY	NOT SHIFTED	SHIFTED	CONTROL CONTROL	CONTROL SHIFT	CAPS LOCK	DOWN CODE	UP CODE
) or 0	30	29	x	x	x	5B	DB
! or 1	31	21	x	x	x	57	D7
@ or 2	32	40	32	00	x	56	D6
# or 3	33	23	x	x	x	55	D5
\$ or 4	34	24	x	x	x	54	D4
% or 5	35	25	x	x	x	53	D3
^ or 6	36	5E	36	1 E	x	52	D2
& or 7	37	26	x	x	x	51	D1
* or 8	38	2A	x	x	x	50	D0
(or 9	39	28	x	x	x	5A	DA

Table B-2 (continued): Hexadecimal Key Codes

KEY	NOT		CONTROL		CAPS LOCK	DOWN CODE	UP CODE
	SHIFTED	SHIFTED	CONTROL	SHIFT			
A	61	41	01	01	41	07	87
B	62	42	02	02	42	13	93
C	63	43	03	03	43	15	95
D	64	44	04	04	44	05	85
E	65	45	05	05	45	0D	8D
F	66	46	06	06	46	04	84
G	67	47	07	07	47	03	83
H	68	48	08	08	48	02	82
I	69	49	09	09	49	08	88
J	6A	4A	0A	0A	4A	01	81
K	6B	4B	0B	0B	4B	00	80
L	6C	4C	0C	0C	4C	10	90
M	6D	4D	0D	0D	4D	11	91
N	6E	4E	0E	0E	4E	12	92
O	6F	4F	0F	0F	4F	19	99
P	70	50	10	10	50	1A	9A
Q	71	51	11	11	51	0F	8F
R	72	52	12	12	52	0C	8C
S	73	53	13	13	53	06	86
T	74	54	14	14	54	0B	8B
U	75	55	15	15	55	09	89
V	76	56	16	16	56	14	94
W	77	57	17	17	57	0E	8E
X	78	58	18	18	58	16	96
Y	79	59	19	19	59	0A	8A
Z	7A	5A	1A	1A	5A	17	97
BACK SPACE	08	x	x	x	x	5F	DF
TAB	09	x	x	x	x	4E	CE
LINE FEED	0A	x	x	x	x	44	C4
RETURN	0D	x	x	x	x	4C	CC
ESC	1B	x	x	x	x	4F	CF

Table B-2 (continued): Hexadecimal Key Codes

KEY	NOT SHIFTED	SHIFTED	CONTROL CONTROL	CONTROL SHIFT	CAPS LOCK	DOWN CODE	UP CODE
space	20	x	x	x	x	45	C5
“							
‘	27	22	x	x	x	48	C8
<							
, (comma)	2C	3C	x	x	x	4D	CD
_ (under score)							
- (hyphen)	2D	5F	2D	1F	X	5C	DC
>							
. (period)	2E	3E	x	x	x	4A	CA
?							
/	2F	3F	x	x	x	4B	CB
:							
: (colon)							
; (semi-colon)	3B	3A	x	x	x	49	C9
+							
=	3D	2B	x	x	x	5D	DD
{							
[5B	7B	1B	7B	x	59	D9
(vert. bar)							
\	5C	7C	1C	7C	x	43	C3
}							
]	5D	7D	1D	7D	x	58	D8
~							
`	60	7E	x	x	x	5E	DE
DELETE	7F	x	x	x	x	42	C2
ENTER	8D	CD	x	x	x	38	B8
HELP	95	D5	x	x	x	46	C6
F0	96	D6	x	x	x	27	A7
F1	97	D7	x	x	x	26	A6
F2	98	D8	x	x	x	25	A5
F3	99	D9	x	x	x	24	A4
F4	9A	DA	x	x	x	23	A3
F5	9B	DB	x	x	x	22	A2
F6	9C	DC	x	x	x	21	A1
F7	9D	DD	x	x	x	20	A0
F8	9E	DE	x	x	x	29	A9
F9	9F	DF	x	x	x	2A	AA
F10	A0	E0	x	x	x	2B	AB
F11	A1	E1	x	x	x	2C	AC
F12	A2	E2	x	x	x	2D	AD
DCHR							
I CHR	A3	E3	x	x	x	2F	AF

Table B-2 (continued): Hexadecimal Key Codes

KEY	NOT SHIFTED	SHIFTED	CONTROL CONTROL	CONTROL SHIFT	CAPS LOCK	DOWN CODE	UP CODE
DEL LINE							
INS LINE	A4	E4	x	x	x	2E	AE
↑	A5	E5	x	x	x	3B	BB
↑	A6	E6	x	x	x	3A	BA
→	A7	E7	x	x	x	33	B3
←	A8	E8	x	x	x	3F	BF
HOME	A9	E9	x	x	x	37	B7
BREAK	AA	EA	x	x	x	47	C7
- (kpd)	AD	ED	x	x	x	39	B9
. (kpd)	AE	EE	x	x	x	40	C0
0(kpd)	B0	F0	x	x	x	41	C1
1 (kpd)	B1	F1	x	x	x	34	B4
2 (kpd)	B2	F2	x	x	x	3C	BC
3 (kpd)	B3	F3	x	x	x	30	B0
4 (kpd)	B4	F4	x	x	x	35	B5
5 (kpd)	B5	F5	x	x	x	3D	BD
6 (kpd)	B6	F6	x	x	x	31	B1
7 (kpd)	B7	F7	x	x	x	36	B6
8 (kpd)	B8	F8	x	x	x	3E	BE
9 (kpd)	B9	F9	x	x	x	32	B2
REPEAT	x	x	x	x	x	60	E0
CAPS LOCK	x	x	x	x	x	61	E1
SHIFT (right)	x	x	x	x	x	62	E2
CTRL	x	x	x	x	x	63	E3
SHIFT (left)	x	x	x	x	x	64	E4

Table B-3: ASCII Keypad Codes - Key Expansion Mode Enabled

KEY(S) PRESSED	MODES			
	NORMAL UNSHIFTED	NORMAL SHIFTED	ALTERNATE UNSHIFTED	ALTERNATE SHIFTED
.ENTER	ENTER	ENTER	ESC?M	ENTER
.	.	.	ESC?n	.
-	-	-	ESC ? m	-
0	0	0	ESC ? p	0
1	1	ESC L	ESC ? q	ESC L
2	2	ESC B	ESC ? r	ESC B
3	3	ESC M	ESC ? s	ESC M
4	4	ESC D	ESC ? t	ESC D
5	5	ESC H	ESC ? u	ESC H
6	6	ESC C	ESC ? v	ESC C
7	7	ESC (@)/ESC 0 ¹	ESC ? w	ESC (@)/ESC 0 ¹
8	8	ESC A	ESC ? x	ESC A
9	9	ESC N	ESC ? y	ESC N
SHIFT ENTER	ENTER	ENTER	ENTER	ESC ? M
SHIFT.	.	.	.	ESC ? n
SHIFT -	-	-	-	ESC ? m
SHIFT 0	0	0	0	ESC ? p
SHIFT 1	ESC L	1	ESC L	ESC ? q
SHIFT 2	ESC B	2	ESC B	ESC ? r
SHIFT 3	ESC M	3	ESC M	ESC ? s
SHIFT 4	ESC D	4	ESC D	ESC ? t
SHIFT 5	ESC H	5	ESC H	ESC ? u
SHIFT 6	ESC C	6	ESC C	ESC ? v
SHIFT 7	ESC @/ESC 0 ¹	7	ESC (@)/ESC 0 ¹	ESC ? w
SHIFT 8	ESC A	8	ESC A	ESC ? x
SHIFT 9	ESC N	9	ESC N	ESC ? y

1. Toggles between codes.

**Table B-4: ASCII Function Key Codes –
Key Expansion Mode Enabled**

<u>KEY PRESSED</u>	<u>UNSHIFTED CODE</u>	<u>SHIFTED CODE</u>
F0	ESC J	ESC E
F1	ESC S	ESC 1 A
F2	ESC T	ESC 1 B
F3	ESC U	ESC 1 C
F4	ESC V	ESC 1 D
F5	ESC W	ESC 1 E
F6	ESC P	ESC 1 F
F7	ESC Q	ESC 1 G
F8	ESC R	ESC H
F9	ESC O I	ESC 1 I
F10	ESC O J	ESC 1 J
F11	ESC O K	ESC 1 K
F12	ESC O L	ESC 1 L
ICHR / D CHR	ESC@ / ESC O ¹	ESC N
DEL LINE / INS LINE	ESC L	ESC M
↑	ESC A	ESC A
↓	ESC B	ESC B
→	ESC C	ESC C
←	ESC D	ESC D
HOME	ESC H	ESC H
BREAK	ESC	ESC I
HELP	ESC ~	ESC -

¹Toggles between codes.

Table B-5: Escape Codes - Cursor Functions

<u>ASCII SEQUENCE</u>	<u>HEXADECIMAL SEQUENCE</u>	<u>DESCRIPTION</u>
ESC A	1B 41	Move the cursor up one line.
ESC B	1B 42	Move the cursor down one line.
ESC C	1B 43	Move the cursor right one position.
ESC D	1B 44	Move the cursor left one position.
ESC H	1B 48	Move the cursor to the upper-left corner of the screen (home position).
ESC I	1B 49	Reverse index (reverse line feed).
ESC Y	1B 59	Direct cursor addressing.
ESC j	1B 6A	Save the current cursor position.
ESC n	1B 6E	Return the cursor position report.
ESC k	1B 6B	Position the cursor to the last position saved.

Table B-6: Escape Codes- Erasing and Editing

<u>ASCII</u> <u>SEQUENCE</u>	<u>HEXADECIMAL</u> <u>SEQUENCE</u>	<u>DESCRIPTION</u>
ESC E	1B 45	Clear the display and move the cursor to the home position.
ESC J	1B 4A	Erase to the end of the page (screen)
ESC K	1B 4B	Erase to the end of the current line.
ESC L	1B 4C	Insert line.
ESC M	1B 4D	Delete line.
ESC N	1B 4E	Delete character.
ESC O	1B 4F	Exit the insert character mode.
ESC @	1B 40	Enter the insert character mode.
ESC b	1B 62	Erase to the beginning of the display.
ESC I	1B 6C	Erase the current line.
ESC o	1B 6F	Erase to the beginning of the current line.

Table B-7: Escape Codes - Modes of Operation

<u>ASCII</u> <u>SEQUENCE</u>	<u>HEXADECIMAL</u> <u>SEQUENCE</u>	<u>DESCRIPTION</u>
ESC F	1B 46	Enter the graphics mode.
ESC G	1B 47	Exit the graphics mode.
ESC =	1B 3D	Enter the alternate keypad mode.
ESC >	1B 3E	Exit the alternate keypad mode.
ESC p	1B 70	Enter the reverse video mode.
ESC q	1B 71	Exit the reverse video mode.
ESC t	1B 74	Enter the keypad shifted mode.
ESC u	1B 75	Exit the keypad shifted mode.

Table B-8: Escape Codes - Configuration

<u>ASCII SEQUENCE</u>	<u>HEXADECIMAL SEQUENCE</u>	<u>DESCRIPTION</u>
ESC r x	1B 72 xx	<u>Modify the baud rate</u>
		<u>x xx BAUD RATE</u>
		A 41 110
		B 42 150
		C 43 300
		D 44 600
		E 45 1200
		F 46 1800
		G 47 2000
		H 48 2400
		I 49 3600
		J 4A 4800
		K 4B 7200
		L 4C 9600
ESC x yy	1B x yy	<u>Set modes</u>
		<u>x yy ACTION</u>
		1 31 Enable the 25th line.
		2 32 Disable key click.
		3 33 Enter the hold screen mode.
		4 34 Enable block cursor.
		5 35 Turn cursor off.
		6 36 Enter keypad shifted mode.
		7 37 Enter alternate keypad mode.
		8 38 Enable automatic line feed when carriage return (CR) is received.
		9 39 Enable automatic carriage return when line feed (LF) is received.
		3B Enable solid (nonblinking) cursor.
		< 3C Disable keyboard automatic repeat.
		? 3F Enable key expansion mode.
		(k 40 Enable event-driven (key up / down) mode.

Table B-8 (continued): Escape Codes- Configuration

<u>ASCII SEQUENCE</u>	<u>HEXADECIMAL SEQUENCE</u>	<u>DESCRIPTION</u>																																										
ESC y x	1B 79 xx	Reset modes																																										
		<table border="1"> <thead> <tr> <th><u>x</u></th> <th><u>xx</u></th> <th><u>ACTION</u></th> </tr> </thead> <tbody> <tr> <td>1</td> <td>31</td> <td>Disable 25th line.</td> </tr> <tr> <td>2</td> <td>32</td> <td>Enable key click.</td> </tr> <tr> <td>3</td> <td>33</td> <td>Exit hold screen mode.</td> </tr> <tr> <td>4</td> <td>34</td> <td>Enable underscore cursor.</td> </tr> <tr> <td>5</td> <td>35</td> <td>Enable cursor.</td> </tr> <tr> <td>6</td> <td>36</td> <td>Exit shifted keypad mode.</td> </tr> <tr> <td>7</td> <td>37</td> <td>Exit alternate keypad mode.</td> </tr> <tr> <td>8</td> <td>38</td> <td>Disable automatic line feed.</td> </tr> <tr> <td>9</td> <td>39</td> <td>Disable automatic carriage return.</td> </tr> <tr> <td>3B</td> <td></td> <td>Enable blinking cursor.</td> </tr> <tr> <td><</td> <td>3C</td> <td>Enable keyboard automatic repeat.</td> </tr> <tr> <td>?</td> <td>3F</td> <td>Disable key expansion mode.</td> </tr> <tr> <td>(6></td> <td>40</td> <td>Disable event-driven mode (key up/down).</td> </tr> </tbody> </table>	<u>x</u>	<u>xx</u>	<u>ACTION</u>	1	31	Disable 25th line.	2	32	Enable key click.	3	33	Exit hold screen mode.	4	34	Enable underscore cursor.	5	35	Enable cursor.	6	36	Exit shifted keypad mode.	7	37	Exit alternate keypad mode.	8	38	Disable automatic line feed.	9	39	Disable automatic carriage return.	3B		Enable blinking cursor.	<	3C	Enable keyboard automatic repeat.	?	3F	Disable key expansion mode.	(6>	40	Disable event-driven mode (key up/down).
<u>x</u>	<u>xx</u>	<u>ACTION</u>																																										
1	31	Disable 25th line.																																										
2	32	Enable key click.																																										
3	33	Exit hold screen mode.																																										
4	34	Enable underscore cursor.																																										
5	35	Enable cursor.																																										
6	36	Exit shifted keypad mode.																																										
7	37	Exit alternate keypad mode.																																										
8	38	Disable automatic line feed.																																										
9	39	Disable automatic carriage return.																																										
3B		Enable blinking cursor.																																										
<	3C	Enable keyboard automatic repeat.																																										
?	3F	Disable key expansion mode.																																										
(6>	40	Disable event-driven mode (key up/down).																																										
ESC z	1B 7A	Reset to power-up configuration																																										

Table B-9: Escape Codes - Additional Functions

<u>ASCII SEQUENCE</u>	<u>HEXADECIMAL SEQUENCE</u>	<u>DESCRIPTION</u>
ESC Z	1B 5A	Identify as a VT52 terminal (1B 2F 4B).
ESC #	1B 23	Transmit the page.
ESC]	1B 5D	Transmit the 25th line.
ESC ^	1B 5E	Transmit the current line.
ESC _	1B 5F	Transmit the character at the cursor.
[ESC i 0	1B 69 30	Identify as Zenith terminal.
ESC m f b	1B 6D xxxx	Set foreground (f) and background (b) colors.

<u>ascii</u>	<u>hex</u>	<u>COLOR</u>
--------------	------------	--------------

0	30	Black
1	31	Blue
2	32	Red
3	33	Magenta
4	34	Green
5	35	Cyan
6	36	Yellow
7	37	White

ESC {	1B 7B	Enable keyboard.
ESC }	1B 7D	Disable keyboard.
ESC v	1B 76	Enable wraparound at end of line.
ESC w	1B 77	Discard at end of line.

Monitor Program Command Summary

The monitor program can perform several functions. One of its primary uses is the load (boot) the disk operating system from disk into memory. The boot command can automatically be activated (autoboot) when the system is turned on if the switch settings in the computer are set appropriately (see Appendix I). Most factory assembled computers are shipped with autoboot activated.

Table C-1 is a summary of the monitor program commands.

Table C-1: Monitor Program Command Summary

<u>COMMAND</u>	<u>NAME</u>	<u>DESCRIPTION</u>
B	Boot	Use this command to load the operating system from a disk.
C	Color bar	Use this command to display a color bar pattern on the screen.
D	Dump	Use this command to display the contents of a block or portion of memory in hexadecimal and ASCII.
E	Examine	Use this command to examine and/or change the contents of memory location(s).
F	Fill	Use this command to fill a specified range of memory locations with data.
H	Help	Use this command or the HELP key to display the list of monitor program commands.
HELP key	Help	See the H command.
I	Input	Use this command to get the contents of a port.
O	Output	Use this command to send a value to a port.
S	System	Use this command to display the system parameters (memory size, video RAM devices, video type: color or monochrome).
T	Test	Use this command to activate the diagnostic test menu.
V	Version	Use this command to display the version number of the ROM program installed in your computer.
E	Execute	Use this command to initiate a machine language program at a specified memory address.

The Monitor Program Commands

To use any monitor program command (except for autoboot), the computer must be in the manual mode. If the computer is set for autoboot, press the DELETE key to disable it right after you turn the computer on or reset it. The hand prompt will be displayed when the computer is in the manual mode.

The monitor program commands, like MS-DOS have a specific syntax which must be followed or the command may not be executed as you intend. In the following material, the syntax notation in Table C-2 is used. If you make a mistake when you enter a command, the computer will beep and wait for you to enter the correct syntax.

Table C-2: Monitor Program Syntax Notation

<u>SYNTAX NOTATION</u>	<u>DESCRIPTION</u>
nnnn	A two-byte value that expresses the start segment address.
mmmm	A two-byte value that expresses the start offset address.
oooo	A two-byte value that expresses the end offset address. A single byte.
[...]	Indicates an optional entry.
x y	Either a choice of <i>x</i> or <i>y</i> .

Boot

The boot command is used to load the operating system from a disk. The following line illustrates the form of the command.

```
B[F1|F2|F3][0|1|2|3][:partition name]
```

The boot command supports up to four drives of each of the three disk types that are available for the Z-100: 5.25-inch floppy disk drives, 8-inch floppy disk drives, and Winchester disk drives. Note that not all operating systems (this includes MS-DOS) support more than 2 of each type of floppy disk drive.

The following procedure illustrates the use of the boot command.

Make sure the computer is on and the hand prompt is showing on the screen.

Press the B key. The computer will display the following.

Boot

Use one of the following three procedures to complete the operation.

1. Press the **RETURN** key. The computer will examine switch S101 on the main board and boot from the device selected by switch section 0, 1, and 2 (see Appendix I). If the device is a floppy disk drive, the computer will attempt to boot the system from the disk in drive zero (drive A or drive C).
2. Press either the **F1**, **F2**, or **F3** key and then the **RETURN** key. The computer will ignore switch S101 and boot from the specified drive type. F1 specifies the 5.25-inch floppy disk drives, F2 specifies the 8-inch floppy disk drives, and F3 specifies the Winchester disk drive. If the device is a floppy disk drive, the computer will attempt to boot the system from the disk in drive zero (drive A or drive C).

You can boot from any drive by entering the drive number (0, 1, 2, or 3) after specifying the drive type by pressing the F1, F2, or F3 key. Number 0 indicates the first drive, 1 indicates the second drive, 2 indicates the third drive, and 3 indicates the fourth drive. However, MS-DOS supports only two drives for each drive type.

To boot the computer from the second 8-inch floppy disk drive, press the B key, the **F2** key, the 1 key, and the **RETURN** key, in that order. If the drive specified is not connected or is faulty (for instance, it may not be turned on), an error message will be displayed after about 30 seconds.

3. You can boot the computer from any partition of the Winchester drive by entering the partition name. Like a floppy disk, the partition must contain an operating system on it or the No system message will be displayed. To boot from a partition, press the B key, the **F3** key, the : (colon) key, and enter the partition name. Then press the **RETURN** key.

Color Bar

The color bar command is used to display a color bar pattern on the screen. To execute this command, press the C key. The screen will clear and a color bar pattern will be displayed along the top half of the screen.

Use this pattern to adjust a color monitor that may be attached to your computer.

If your computer does not have a color monitor attached to it, the monochrome display will show a gray-scale pattern with black on the left side of the screen gradually increasing in brightness to white on the right side of the screen.

If your computer does not have the color option installed or selected, a white box will fill the upper-right quarter of the screen.

Dump

The dump command is normally used by machine language programmers to display the contents of a block (256 bytes) or portion of memory in hexadecimal and ASCII. Use the following format for the dump command.

D[nnnn:mmmm-oooo]

If you do not enter the addresses, the computer will display a block of 256 bytes, starting with the last-displayed address (+ 1). When you first turn on the computer, the starting address will be 0:0.

Examine

The examine command is used by machine language programmers to examine and/or change the contents of memory location(s). Use the following format for the examine command.

E[nnnn:mmm]

When you enter an address, the computer will display the hexadecimal value that is stored at that memory location. If you do not enter a number at this point, but press the RETURN key, no changes to memory are made and the next address and value will be displayed. If you do enter a number, it will be stored in the memory location specified by the displayed address and then the next address and the value stored there will be displayed. To exit the command, press the **DELETE** key.

Fill

The fill command is used by machine language programmers to fill a specified range of memory locations with data. Use the following format for the fill command.

Fnnnn:mmm-ooo,nn

When you enter this command, the entire memory range will be filled with the hexadecimal byte, *nn*. This command can be used to clear memory (enter 00 for byte value).

Help

This command is used to display the list of monitor program commands. When you press either the H key or the HELP key, the following will be displayed:

- Boot
- Color Bar
- Dump
- Examine
- Fill
- Help
- <HELP Key>
- Input
- Output
- System
- Test
- Version
- Xecute

Input

This command is used to retrieve a byte of data at a port. Use the following format to execute the input command.

Iport

The single byte at port *nn* will be returned as a hexadecimal value.

Output

This command is used to send a value to a port. Use the following format ;to execute the output command.

Oport,nn

The value *nn* will be sent to the specified *port*.

System

This command is used to display the system parameters (memory size, video RAM devices, and video type: color or monochrome). To use the command, press the S key. The computer will display a message similar to the following.

```
128Kb of contiguous RAM
32Kb Video memory
Monochrome
```

The memory capacity (RAM) is measured in 64Kb increments. The video memory may be either 32Kb or 64Kb. The video type may be either monochrome (as shown) or color.

Test

This command is used to display the diagnostic test menu. The tests can help you isolate a problem or make sure that the various sections of the computer are operating correctly. To display the test menu, press the T key. The computer will display the following menu.

```
CHOOSE ONE OF THE FOLLOWING
```

1. DISK READ TEST
2. KEYBOARD TEST
3. MEMORY TEST
4. POWER-UP TEST
5. EXIT

```
ENTER YOUR CHOICE:
```

Press the key that corresponds to the test you want to run. The following describes each test.

- Disk read test - This test repeatedly reads the boot tracks and writes it into memory. Each time the test is successfully completed, a counter (displayed on the screen) is incremented by one. If an error occurs, the test will stop.

- Keyboard test - This test fills the screen with the character that you enter on the keyboard. If you press a key that does not correspond to a printable character (for instance, if you press the RETURN key or LINE FEED key), the screen will display the message NON-DISPLAYABLE CHARACTER.
 - Memory test - This test performs a moving inversion test on the first two banks of memory and the green bank of video memory if 64-kilobit parts are installed. If 32-kilobit parts are installed, a different test is used. If an error occurs, the test is halted. Otherwise, you will hear a tick, which indicates the test is running. The test is rather lengthy and so the counter displayed on the screen will be updated about every five minutes.
 - Power-up test - This test repeats the initial self-tests that the computer performs each time it is turned on. The test will continue until an error is detected.
- If you want to stop any test, press the **DELETE** key. However, if you are running the memory test, up to five minutes may pass before the system will respond. To stop the memory test in less time, press the **CTRL** and **RESET** keys to reset the computer.

Version

This command is used to display the version number of the ROM program installed in your computer. To use the command, press the V key. The computer will display the version number of the ROM.

Execute

This command is used by machine language programmers to run a machine language program at a specified memory address. The command sets the CS:IP to the address specified and then performs a jump to that address. Once you execute this command, the only way control can be returned to the monitor is by a command from the program being executed or by resetting the computer.

MS-DOS Command Summary

This appendix contains a summary of the control key combinations and commands that are available while you are using MS-DOS on the Z-100 Computer.

In addition, it contains instructions for using these commands if you only have one disk drive in your computer.

Table D-1 is a summary of the control key functions active while using MS-DOS.

Table D-1: Control Key Functions

<u>KEY(S) PRESSED</u>	<u>ACTION</u>
BACK SPACE	Back space and delete character.
CTRL-C	Exit from the current function.
CTRL-N	Disable printer echo.
CTRL-P	Enable printer echo.
CTRL-S	Suspend all operation. Press any key to continue.
CTRL-X	Cancel current line.
LINE FEED	Extend current logical line to next physical line.
RETURN	Execute current command line.
TAB	Move cursor to next tab column.

Command Summary

Table D-2 is a summary of the filename conventions.

Table D-2: File Name Conventions

<u>NAME</u>	<u>DESCRIPTION</u>	<u>EXAMPLES</u>
[...]	Optional parameter	[comment][filename]
<...>	Specified parameter	<filename>
filespec	device with filename	B: BIN\ABODE.MAC
d:	drive name	A: B: C: D:
pathname	name of directory path	BIN\ DEV\ DEVEL\
filename	name of file	MYPROG OLDFILE
	either/or	ON OFF

Commands

<filename>.BAT[<parameters>]

Execute a file with a.BAT extension as a batch processing file.

APPLY [d:]<filespec><command>[/switch]

Execute a given command multiple times, substituting a selected parameter.

Switch: /S Silent - suppress the display of command lines executed through the APPLY command.

ASSIGN [<hardware unit:>][<partition name>[<;system name>] d:]

Assign a logical drive name to a Winchester disk partition.

BACKUP [filespec[+ filespec ...]] [d :][filename][/switch]

Create a single archive file from one or more active files.

Switches:

- /A Back up files with date after that specified.
- /B Back up files with date before that specified.
- /D Display (as a directory) all master backup files.
- /E Back up files except those specified.
- /F Format destination disks automatically.
- /G Backup files in all subdirectories as well as the current directory.
- /L List directory of the backup file.
- /N Do not format destination disks.
- /O Query yes/no for each file to be backed up.
- /R Review selected files before backing them up.
- /T Back up files with current system date.
- /V Verify backup files after copy.
- /W Back up files that have been written since last backed up.

BREAK [ON/OFF]

Turn on or off "check for CTRL-C" whenever system access is performed.

CD

See CHDIR.

CHDIR [d:][pathname]

Change or display the current directory.

CHKDSK [d:][filename][/switch]

Examine directory and file allocation table and report status.

Switches /F Fix any common disk errors.

/V Display status messages and disk directory.

CIPHER <keyword> >j< filespec[1] [> filespec[2]]

Encrypt or decrypt a file.

CLS

Clear the screen.

COMMAND [d:][pathname][ctty device][/switch]

Execute the command processor.

Switches: /C Execute specified string as a command.

/D Disable time and date prompt.

/P Place COMMAND.COM in system memory.

CONFIGUR

Configure system input/output parameters.

COPY <filespec> [d :] <filename|pathname>[/switch]

Copy one or more files.

Switches: /V Verify copy operation.

CREF

Build a cross reference file.

CTTY <device>

Change command input/output device to AUX or CON.

DATE [M/D/Y]

Display and/or change current system date.

DEBUG

Activate the debugging utility.

DEL

See ERASE.

DIR [d:][<filespec>|<pathname>][/switch]

Display all or selected entries of the current or specified directory.

Switches: /P Page mode.
/W Wide display mode.

DISKCOMP [d: [d:]]

Compare two disks.

DISKCOPY[/switch] [d: [d:]]

Duplicate a disk.

Switch: /V Verify duplication operation.

ECHO [ON |OFF| message]

Control display during batch processing.

EDLIN

Create and maintain ASCII text file.

ERASE <filespec>|<[d:]<pathname>[\<filespec>]

Delete (erase) one or more files/paths.

EXE2BIN <filespec> [filespec]

Convert .EXE file to binary format (.COM).

EXIT

Exit the command processor to previous level.

FC[/switch] <filespec1 > <filespec2>

Compare two files.

Switches: /B Binary comparison.
/C Ignore upper- and lowercase differences.
/# Number of lines to be compared for a match.
/W Compress white space.

FIND[/switch] string [filespec...]

Search for a string in one or more files.

Switches: /C Count lines (display number of lines that have string).
/I Ignore upper- and lowercase differences.
/N Display line number(s) where string was found.
/V Display lines that do not have string.

FONT [filespec]

Enable font editor or load alternate character set.

FOR ... IN ... DO ...

Loop processing feature of batch processor.

FORMAT [d :]/[switch]

Formats disk surface.

Switches: /A Format 8-inch disk as single-sided, single-density
/C Do not format disk, but initialize directory only
/9 Format 5.25-inch disks using 9 sectors per track
/M Format disk as single-sided
/N Suppress operator prompts
/S Record system files on disk
/V Verify format and lock out bad sectors

GOTO ...

Unconditional branch feature of batch processor.

IF [NOT]

Conditional feature of batch processor.

LIB

The library manager.

LINK

Creates executable files from object code.

MAP [d:u [...]]

Reassign logical drive names to different physical drive.

MD

See MKDIR

MKDIR [d:]pathname

Create a directory.

MORE

Send output one screen at a time.

PATH [d:][pathname[:[d:]pathname]...]

Specify directory or directories to be searched to execute external MS-DOS commands.

PAUSE [comment]

Suspend action of batch processor.

PRINT <filespec[/switch]> [filespec[/switch]]...

Initiate background printing of file(s).

Switches:

- /A Do not print specified files in the queue until /S is encountered.
- /Cn Print n copies of specified file(s).
- /F Form feed at end of specified file(s).
- /Ln Set left margin to n.
- /Pn Set page length to n.
- /Rn Set right margin to n.
- /S Turn spooler back on (after /A switch).
- /T Terminate printing.

PROMPT [\$][text]

Change MS-DOS system prompt.

PSC[printer name]

Load screen dump utility into memory.

RDCPM [DIR d:[filespec][[/switch]<filespec1 >[filespec2][[/switch]

Read CP/M directories or copy CP/M files to MS-DOS.

Switch: /Z Copy from Zenith CP/M formatted disk.

RECOVER d:[filespec]

Recover file(s) that have been erased or deleted from the disk.

REM [remark]

Display message during batch processing.

REN

See RENAME.

RENAME <filespec> <filename> Rename a file.

RESTORE [filespec[filespec[+filespec...]]][/switch]

Restore archived files.

Switches: /A Restore files with date after that specified.
/B Restore files with date before that specified.
/D Display all archive files.
/E Do not restore specified files.
/F Restore all files to current directory.
/L List directory of archive file contents.
/M Restore files to specified drive.
/O Overwrite existing files on destination disk.
/Q Query yes/no for each file in archive file to be restored.
/R Review selected files.
/T Restore only files with current system date.
/V Verify files after restoration.

RD

See RMDIR.

RMDIR [d:]pathname

Remove specified directory.

SEARCH [filespec][/switch]

Locate a file.

Switches: /C Search current directory only.
/D List directories as they are searched.
/T Display directory structure as searched.

SET [string = (string = string]

Set one string equivalent to another.

SHIFT

Allows more than 10 parameters in batch processor.

SORT [/switch]

Displays results in sorted order.

Switches: /R Reverse order (Z to A).

/+n Start sort key at column n.

SYS d:

Transfer MS-DOS system files from default drive disk to destination disk.

TIME [h:m:s.c]

Display and/or change current system time.

TYPE <filespec>

Display contents of specified file.

VER

Display the version numbers of MSDOS.SYS and IO.SYS.

VERIFY [ON|OFF]

Display or change condition of verify function.

VOL[d:]

Display volume name of disk in default or specified drive.

MS-DOS With Single Drive Computers

In the "Disk Operating System" chapter of this manual, we explained in detail how to use some of the MS-DOS commands with computers that have two disk drives. If your system has only one floppy disk drive, there are some things you need to know.

- All instructions are identical for single-drive and two-drive systems.
- Your computer "thinks" it has two 5.25-inch floppy disk drives even if it has only one.
- You will be prompted by your computer to swap disks whenever necessary.

As long as you remember that you must insert the proper disk into the single 5.25-inch disk drive when prompted, everything will be fine. If you insert the wrong disk, you may have problems (such as incomplete copies and/or damaged files).

The two prompts you will see follow.

Place disk B in drive A. Place disk A in drive A.
Press any key when ready. Press any key when ready.

Any command that can access more than one drive will be affected. These commands include: DIR, RENAME, ERASE, COPY, TYPE, CHKDSK, FORMAT, and DISKCOPY.

A sample of handling the DISKCOPY command to duplicate a disk follows. The computer will show the following, after you turn it on and boot MS-DOS.

A>

- Enter the following command line.

DISKCOPY/V A: B:

- Press the **RETURN** key. The computer will read the utility into memory from the disk. Then, it will show a display similar to the following.

DISKCOPY version 2.20
Copyright(C) 1984 Zenith Data Systems Corporation

Place source disk in drive A and destination disk in drive B.
Press RETURN when ready.

- Since you don't have drive B, place the source disk in your only drive and press the **RETURN** key. The computer will display a message similar to the following.

Formatting destination... Place disk B in drive A.
Press any key when ready.

- Remove the source disk from your disk drive.
- Insert the destination disk in the drive and press any key (most people use the RETURN key). After about a minute, the computer will display the following message.

Copy... Place disk A in drive A. Press any key when ready.

- Now remove your destination disk and insert your source disk in the disk drive and press any key. The computer will sound a tone and display the following message.

Place disk B in drive A. Press any key when ready.

- Swap disks and press any key. Again the computer will sound a tone and display the message to exchange disks.

Here is what is happening: the computer is reading sections of the source disk into memory. When it has finished reading a section of the source disk, the computer will attempt to write (record) that same information onto the destination disk. Since you have only one drive, the computer senses this and prompts you to exchange disks. You must exchange disks because the operating system will not check to make sure you did.

- Swap disks each time the computer prompts you to exchange disks. After you have swapped disks all of the times needed to duplicate the disk, the computer will start the verification process. Again, it will prompt you to swap disks as it reads the contents of each disk and compares them to make sure that they are the same. When the entire process is finished, the computer will return you to the operating system prompt.

The operation is complete. If you want to copy a file which contains a lot of information or if you want to copy more than one file, you will be prompted to change disks more than once.

If your computer has one 5.25-inch disk and either 8-inch disks or a Winchester disk system, you may want to use the larger-capacity systems as a temporary storage device when you duplicate 5.25-inch disks. If this is the case, you must use the FORMAT and COPY commands instead of the DISKCOPY command. DISKCOPY will not duplicate disks that do not have the same physical characteristics.

BASIC Command Summary

This appendix contains a summary of Z-BASIC and GW-BASIC, version 2. Included are the control characters, commands, statements, functions, and characteristics for these two versions of BASIC.

Table E-1 provides a list of the control character combinations recognized by BASIC.

Table E-1: Control Characters

<u>CONTROL CHARACTER</u>	<u>Z-BASIC</u>	<u>GW-BASIC</u>	<u>DESCRIPTION</u>
CTRL-A	x	n/a	Prints the last line entered (not including the line number).
CTRL-B	x	x	Moves the cursor one word to the left.
CTRL-C	x	x	Interrupts program execution and returns control to the BASIC command level.
CTRL-E	x	x	Erases line from cursor to the end of the line.
CTRL-F	x	x	Moves the cursor one word to the right.
CTRL-G	x	x	Sounds a tone from the speaker.
CTRL-H	x	x	This combination has the same action as the BACK SPACE key. It moves the cursor one position to the left and deletes the character.
CTRL-I	x	x	This combination has the same action as the TAB key. It moves the cursor to the next tab stop (every eighth column).
CTRL-J	x	x	This combination has the same action as the LINE FEED key. It acts as a continuation of the logical line, but starts subsequent text at the beginning of the next physical line.
CTRL-L	x	x	This combination has the same action as the CLS statement. The screen is cleared and the cursor is moved to the home position (location 1,1).
CTRL-M	x	x	This combination has the same action as the RETURN key. Any direct statement will be executed and any indirect statement (program line) will be saved.
CTRL-N	x	x	Moves the cursor to the end of the current program line.
CTRL-P	n/a	x	Toggles printer echo on or off.
CTRL-R	n/a	x	This combination has the same action as the INS LINE key. The insert mode is toggled on or off.
CTRL-S	x	x	Suspends program execution.
CTRL-T	x	x	Toggles the display of the function keys on the 25th line.

Table E-1 (continued): Control Characters

CONTROL CHARACTER	Z-BASIC	GW-BASIC	DESCRIPTION
CTRL-Q	x	x	Resumes program execution after being suspended by CTRL-S.
CTRL-W	x	x	Deletes the word at the current cursor position.
CTRL-U	x	n/a	Deletes the line that is currently being typed.
CTRL-X	n/a	x	Displays the previous program line.
CTRL-Y	n/a	x	Displays the next line.
CTRL-Z	x	x	Clears from the current cursor position to the end of the screen.
(CTRL-RESET	x	x	Resets the computer. This reset cannot be disabled by disabling the keyboard.
Left arrow	x	x	Moves the cursor one character to the left.
Right arrow	x	x	Moves the cursor one character to the right.
Up arrow	x	x	Moves the cursor up one line.
Down arrow	x	x	Moves the cursor down one line.
HOME	x	x	Moves the cursor to the home position.
ICHR	x	n/a	Toggles insert mode on/off.
INS	n/a	x	Toggles insert mode on/off.
DCHR	x	n/a	Deletes character at cursor position.
DELETE	x	n/a	Deletes character at cursor position.
DEL	n/a	x	Deletes character at cursor position.
BACKSPACE	x	x	Deletes character to left of cursor.
TAB	x	x	Moves cursor to next tab column.

Table E-2: Variable Specifications

VARIABLE TYPE	RANGE	NUMBER OF DIGITS	EXPONENTIAL FORM	VARIABLE DECLARATION SYMBOL
Integer	-32768 to 32767	n/a	n/a	&
Single precision	10E-38 to 10E + 38 6 (stored)	7 (printed)	E	!
Double precision	10D-38 to 10D + 38 16 (stored)	17 (printed)	D	#
String	n/a	255	n/a	\$
Hexadecimal prefix	&H			
Octal prefix:	&O			

Table E-3: Arithmetic Operators

<u>OPERATOR</u>	<u>DESCRIPTION</u>
^	Exponentiation
-	Negation
*	Multiplication
/	Floating point division
\	Integer division
MOD	Modulus arithmetic
+	Addition
-	Subtraction

Table E-4: Relational Operators

<u>OPERATOR</u>	<u>DESCRIPTION</u>
=	Equality
<>	Inequality
<	Less than
>	Greater than
<=	Less than or equal to
>=	Greater than or equal to

Table E-5: Logical Operators

<u>OPERATOR</u>	<u>EXAMPLE</u>	<u>DESCRIPTION</u>
AND	A AND B	The logical product of A and B. A AND B has the value of true only if A and B are both true. A AND B has the value of false if either A or B is false.
EQV	A EQV B	A is logically equivalent to B. A EQV B is true if A and B are both true or both false; otherwise, A EQV B is false.
IMP	A IMP B	The logical implication of A and B. A IMP B is false if and only if A is true and B is false; otherwise, the value is true.
NOT	NOT A	The logical negative is A. If A is true, NOT A is false.
OR	A OR B	The logical sum of A and B. A OR B has the value of true if either A or B is true. A OR B has the value of false if both A and B are false.
XOR	A XOR B	The logical exclusive OR of A and B. A XOR B is true if either A or B (but not both) is true; otherwise, A XOR B is false.

Table E-6: Truth Table for Logical Operators

<u>X</u>	<u>Y</u>	<u>NOT X</u>	<u>X AND Y</u>	<u>X OR Y</u>	<u>X XOR Y</u>	<u>X IMP Y</u>	<u>X EQV Y</u>
1	1	0	1	1	0	1	1
1	0	0	0	1	1	0	0
0	1	1	0	1	1	1	0
0	0	1	0	0	0	1	1

Table E-7: BASIC Color Attributes

<u>COLOR NUMBER</u>	<u>COLOR</u>
0	Black
1	Blue
2	Green
3	Cyan
4	Red
5	Magenta
6	Yellow
7	White

Table E-8: String Operators

<u>OPERATOR</u>	<u>DESCRIPTION</u>
+	Concatenation Equality
<> Inequality	Less than Greater than
=	Less than or equal to
=	Greater than or equal to

Table E-9: Arrays

<u>SPECIFICATION</u>	<u>Z-BASIC</u>	<u>GW-BASIC</u>
Number of dimensions	255	255
Number of elements/dimension	32766	32767

BASIC Commands, Functions, and Statements

In the following summary, variables are represented by X, Y, Z, and the variable declaration symbol where used.

ABS(X)

A function that returns the absolute value of X.

ASC(X\$)

A function that returns the first character in the string as an ASCII value.

ATN(X)

A function that returns the arctangent of X, a value in radians.

AUTO [line#], [increment]

A command that enables automatic line numbering.

BEEP

A statement that causes a tone to be sounded from the speaker.

BLOAD filespec [,memory location (offset)]

A command that loads a memory image file into memory.

BSAVE filespec, memory location (offset), file length

A command that saves a portion of memory onto disk.

CALL X [argument(s)]

A statement that executes a machine language program.

CDBL(X)

A function that returns the double-precision value of X.

CHAIN [MERGE] filespec [, [line number][,ALL][,DELETE range]

A statement that loads another program into memory and allows variable values to be passed.

CHDIR pathname

A statement that changes the directory of the default disk (GW-BASIC only).

CHR\$(X)

A function that converts the value X to the equivalent ASCII character.

CINT(X)

A function that converts the value X to an integer value after rounding the decimal portion.

CIRCLE(X,Y),radius[,color[,start, end[,aspect]]]

A statement that draws a circle with a center point of X,Y and the radius, color, starting and ending points, and aspect ratio specified in the parameters.

CLEAR[[high memory (Z-BASIC)|work space (GW-BASIC)][,stack space]]

A statement that initializes variables, sets the high memory location for Z-BASIC or the work space size for GW-BASIC, and sets the stack space for the BASIC interpreter (default is 256 bytes in Z-BASIC and 512 bytes in GW-BASIC).

CLOSE [file number(s)]

A statement that closes opened files.

CLS

A statement that clears the screen and moves the cursor to the home position (location 1,1).

COLOR [foreground][, background]

A statement that allows you to change the foreground and background colors (see Table E-7).

COM(n) ON|OFF|STOP

A statement that enables or disables the trapping of communication activity at the specified port.

COMMON variable(s)

A statement that passes variables to a program that has been chained to the current program.

CONT

A command that allows a halted program (where execution has been suspended by a STOP statement or the CTRL-C key combination) to be continued.

COS(X)

A function that returns the cosine of X, a value in radians.

CSNG(X)

A function that returns the single-precision value of X.

CSRLIN

A function that returns the current row (line) location of the cursor.

CVD(X\$)

A function that returns the double-precision numeric value of the eightbyte string X\$.

CVI(X\$)

A function that returns the integer numeric value of the two-byte string X\$.

CVS(X\$)

A function that returns the single-precision numeric value of the fourbyte string X\$.

DATA constant(s)

A statement that stores constant values which may be read by the READ statement.

DATE

A function that returns the day of the year currently stored in the computer (Z-BASIC only).

DATE\$[= X\$]

A statement that sets or retrieves the date stored in the computer.

DEF FNname[(arguments)] = expression

A statement that names and defines a function.

DEF SEG[=segment]

A statement that assigns a memory segment for used by BLOAD, BSAVE, CALL, USR, PEEK, and POKE.

DEF USRn = memory location

A statement that assigns a memory location in the segment for a machine language routine.

DEFDBL variable(s)

A statement that declares variables as double-precision.

DEFINT variable(s)

A statement that declares variables as integers.

DEFSNG variable(s)

A statement that declares variables as single-precision.

DEFSTR variable(s)

A statement that declares the variables as strings.

DELETE[line number][-line number]

A command that deletes the specified line number(s).

DIM variable(s)

A statement that sets up limits for arrays.

DRAW X\$

A statement that draws the pattern specified in X\$. Refer to Table E-1 0 for a description of the directions recognized by the DRAW statement. The distance moved, indicated by *n in* the table, is determined by the scale factor.

Table E-10: Directions Recognized by the DRAW Statement

<u>LETTER</u>	<u>DESCRIPTION</u>
<i>Un</i>	Move up <i>n</i> places.
<i>Dn</i>	Move down <i>n</i> places.
<i>Ln</i>	Move left <i>n</i> places.
<i>Rn</i>	Move right <i>n</i> places.
<i>En</i>	Move up and right <i>n</i> places.
<i>Fn</i>	Move down and right <i>n</i> places.
<i>Gn</i>	Move up and left <i>n</i> places.
<i>Hn</i>	Move up and right <i>n</i> places.
<i>Mx,y</i>	Move $\pm x$ places and $\pm y$ places (absolute or relative).
<i>Aang/e</i>	Set angle; 0 = 0 degrees, 1 = 90 degrees, 2 = 180 degrees, 3 = 270 degrees.
<i>B</i>	Move but do not plot any points (invisible movement).
<i>N</i>	Move but return to original starting position. <i>Cn</i> Set color to <i>n</i>
<i>Sn</i>	Set scale factor to <i>n</i> . This factor is multiplied with the movement number to obtain the actual distance (in pixels) moved.
<i>X</i>	string Execute substring.
<i>TAn</i>	Turn the angle $\pm n$ degrees (range is ± 360 degrees). <i>GW-BASIC</i> only.
<i>Pc,b</i>	Fill the figure with the color <i>c</i> , bordered by the color <i>b</i> .

EDIT line number |.

A command that displays the specified line for editing. Refer to Table E-1 for the control characters that are used to edit BASIC program lines.

ELSE

A statement that is part of the IF ... THEN ... ELSE statement.

END

A statement that terminates program execution.

ENVIRON parameter

A statement that modifies the MS-DOS through the GW-BASIC environment string table (GW-BASIC only).

ENVIRON\$ parameter

A function that returns the contents of the GW-BASIC environment string table (GW-BASIC only).

EOF(file number)

A function that returns a true (-1) if the end of file marker has been reached.

ERASE array name(s)

A statement that erases arrays.

ERDEV

A function that returns the numeric value representing an error which has occurred in a device (see ERDEV\$). GW-BASIC only.

ERDEV\$

A function that returns the name of the device in which an error has occurred. (see ERDEV). GW-BASIC only.

ERL

A function that returns the line in which an error has occurred (see ERR).

ERR

A function that returns the numeric value representing an error which has occurred (see ERL).

ERROR X

A statement that simulates an error, the value of which is X.

EXP(X)

A function that returns the exponential value of X.

FIELD #n, nn as X\$

A statement that allocates buffer space for local variables.

FILES X\$

A statement that will list the file(s) on the (default) disk.

FIX(X)

A function that returns the truncated integer value of X.

FOR X = n1 TO n2 [STEP n3]...NEXT X

Statements (FOR and NEXT) that provide for a repetitive execution loop.

FRE(0)

A function that returns the number of bytes of unused memory recognized by BASIC.

GET *n*, record number

A statement that retrieves a record from a disk file or, in GW-BASIC only, a communications file, and places it in a buffer.

GET (X1,Y1)-(X2,Y2),X

A statement that moves a screen image to an array.

GOSUB line number ... RETURN

Statements that control branching to a subroutine and return to the main program.

GOTO line number

A statement that unconditionally branches to another part of the program being executed.

HEX\$(X)

A function that returns the hexadecimal value of X.

IF expression THEN ... ELSE...

A statement that provides a conditional branch or execution of the program.

INKEY\$

A function that returns a character from the keyboard buffer.

INP(port)

A function that returns a byte from the port.

INPUT[prompt;|,]variable...

A statement that accepts data from the keyboard.

INPUT\$(X[,Y])

A function that returns X characters from the keyboard or file Y.

INPUT #*n*

A statement that retrieves data from sequential file *n*.

INSTR([nn,]X\$,Y\$)

A function that returns the first location of Y\$ in X\$, starting at nn.

INT(X)

A function that returns the largest integer of X.

IOCTL #n,X\$

A statement that sends control data (X\$) to a file device (GW-BASIC only).

IOCTL\$ #n

A function that returns control data (X\$) from a file device (GW-BASIC only).

KEY[n,X\$j][LISTjONjOFF]

A statement that sets or displays the programmable function keys.

KEY(n) ON|OFF|STOP

A statement that enables or disables branching when a function key is pressed.

KILL filespec

A command that deletes the specified file(s) from the disk.

LEFT\$(X\$,nn)

A function that returns the left nn character(s) of X\$.

LEN(X\$)

A function that returns the number of characters in X\$.

[LET]variable = expression

A statement that assigns the value of the expression to the variable.

LINE [(X1,Y1)-(X2,Y2)[,color][,Box][Fill]][,mask]

A statement that draws a line, square, or box. Mask is only available in GW-BASIC.

LINE INPUT[prompt;j,]X\$...

A statement that accepts data from the keyboard.

LINE INPUT #n,X\$

A statement that reads data from a sequential file.

LIST [line number][-[line number]]

A command that lists the program or specified lines to the screen.

LLIST [line number][-[line number]]

A command that lists the program or specified lines to the printer.

LOAD filespec[,R]

A command that loads (and executes, with the R parameter) a program from disk.

LOC(n)

A function that returns the current position in the specified file.

LOCATE [row][, [column][,cursor on/off]]

A statement that positions the cursor to the designated row and column.

LOF(n)

A function that returns the number of bytes allocated to the specified file.

LOG(X)

A function that returns the natural logarithm of X.

LPOS(n)

A function that returns the current position of the print head.

LPRINT expression(s)

A statement that sends data to the printer.

LPRINT USING A\$;X

A statement that sends formatted data to the printer.

LSET A\$ = expression

A statement that assigns data in the expression to A\$.

MERGE filespec

A command that merges a program from disk with the one in memory.

MID\$(X\$,i,nn)

A function that returns the string of *nn* characters starting at *i* in X\$.

MID\$(X\$,nn,i) = Y\$

A statement that replaces *nn* characters of X\$ starting at *i* with Y\$.

MKDIR pathname

A statement that creates a directory on the specified disk (GW-BASIC only).

MKD\$(X)

A function that returns the eight-byte string representation of the doubleprecision variable X.

MKI\$(X)

A function that returns the two-byte string representation of the integer variable X.

MKD\$(X)

A function that returns the four-byte string representation of the singleprecision variable X.

NAME oldfile AS newfile

A statement that renames the disk file oldfile with the name newfile.

NEW

A command that deletes the program in memory.

NULL *nn*

A statement that sets *nn* nulls to be printed at the end of each line (Z-BASIC only).

OCT\$(X)

A function that returns the octal value of X.

ON COM(n) GOSUB line number

A statement that transfers program control to a subroutine when a communication channel is active.

ON ERROR GOTO line number

A statement that enables error trapping to a subroutine.

ON expression GOSUB line number(s)

A statement that evaluates the expression and transfers program control to the subroutine(s).

ON expression GOTO line number(s)

A statement that evaluates the expression and transfers program control to the line(s) specified.

ON KEY(n) GOSUB line number

A statement that enables key trapping and transfers program control to a subroutine when the specified function key is pressed.

ON PEN GOSUB line number

A statement that enables program control transfer to a subroutine when the light pen is activated (GW-BASIC only).

ON TIMER (n) GOSUB line number

A statement that transfers control to the subroutine after n seconds (GW-BASIC only).

OPEN "mode",n,"device filespec"[,record length]

A statement that opens a file for input and/or output.

OPEN "device filespec" [FOR mode] AS n [LEN = record length]

A statement that opens a file or device for input and/or output.

OPEN "COMn:[speed][,[parity][,[word size][,[stop bits]]][,LF][,ASC]"AS n [LEN = record length]

A statement that opens a communication channel for input and output.

OPTION BASE n

A statement that sets the minimum value for array subscripts (0 or 1).

OUT port,byte

A statement that sends a byte to a port.

PAINT (X,Y)[,[color][,border]

A statement that fills an area starting at X,Y with the specified color and limited by a border of the specified color. This statement, in GW-BASIC only, permits paint tiling.

PEEK (memory location)

A function that returns the byte at the specified memory location.

PEN(n)

A function that returns the light pen coordinates or status (GW-BASIC only).

PEN ON|OFF|STOP

A statement that enables or disables the PEN function and trapping routines (GW-BASIC only).

PMAP(point coordinate,n)

A function that maps physical coordinates to world coordinates or vice versa (GW-BASIC only).

POINT(X,Y)|(n)

A function that returns the color of the specified point or the current coordinate(s).

POKE memory location,byte

A statement that places the specified byte into the specified memory location.

POS(0)

A function that returns the current column position of the cursor.

PRESET(X,Y)[,color]

A statement that resets the point at the specified coordinates to the background or specified color.

PRINT expression(s)

A statement that sends data to the screen.

PRINT USING A\$;X

A statement that send formatted data to the screen. Table E-1 1 contains the descriptions of the field specifiers.

Table E-11: USING Field Specifiers

<u>FIELD SPECIFIER</u>	<u>DESCRIPTION</u>
!	Prints the first character of the string.
\nnn\	Prints two + <i>nnn</i> characters of the string.
&	Prints the entire string.
#	Specifies a digit location.
.	Specifies the decimal point location.
+	Prints the sign if negative or positive. This symbol also specifies the location of the sign (either preceding or following the value).
-	Prints the sign, only if negative, following the value.
**	Fills leading spaces with asterisks.
\$\$	Prints the leading dollar sign.
*\$	Prints a leading dollar sign and fills the remaining leading spaces with asterisks.
,	Prints a comma to the left of every third digit on the left side of the decimal point.
^ ^ ^ ^	Specifies exponential format.
_	Specifies that the next character is a literal character.

PRINT *n*,*X*

A statement that sends data to a sequential file.

PRINT *n*, USING A\$,*X*

A statement that sends formatted data to a sequential file. See Table E-1 1 for the field specifiers.

PSET (*X*,*Y*)[,*color*]

A statement that sets a point at coordinates *X*,*Y* to the specified color.

PUT *n*, record number

A statement that records data from buffer *n* to the specified disk record number or to a communications device (record number then specifies the number of bytes).

PUT (*X1*,*Y1*)-(*X2*,*Y2*),*X*,*verb*

A statement the transfers an image stored in memory to the screen. The verbs that may be used with this command are described in Table E-12.

Table E-12: Image Transfer Action Verbs

<u>VERB</u>	<u>DESCRIPTION</u>
PSET	Transfer the image verbatim (without any modification).
PRESET	Transfer the image and make it negative. Bit values are inverted.
AND	Transfer those portions of the stored image that exist in the existing image.
OR	Superimpose the stored image onto existing image.
XOR	Used for animation. It causes the points on the screen to be inverted where a point exists in the array image. When XOR is used to put an image on a complex background <i>twice</i> , the background is restored intact.

RANDOMIZE(X|TIMER)

A statement that seeds the random number generator. The timer function is available only under GW-BASIC.

READ variable(s)

A statement that reads and assigns values (from corresponding DATA statements) to variables.

REM remark(s)

A statement that allows a remark to be placed in the middle of a program. The single quote mark may be used in place of the REM statement. Remarks that fall in a program line must be the last statement in that line.

RENUM new number, old number, increment

A command that will renumber the lines of the program in memory.

RESET

A command that will close all open disk files and update the disk directory. This command is intended to be used on a system before the disk is removed from the disk drive.

RESTORE [line number]

A statement that will reset the data pointer to the beginning or a specified line in the DATA statements.

RESUME[0|NEXT|line number]

A statement that transfers program control: to the statement that caused the error; to the statement immediately following that which caused the error; or to the specified line number.

RETURN[line number]

A statement that transfers program control from a subroutine back to the main program or to the specified line.

RIGHT\$(X\$,nn)

A function that returns the right *nn* characters of X\$.

RMDIR path name

A statement that removes the specified directory from the disk (GW-BASIC only).

RND[(X)]

A function that returns a random number between 0 and 1.

RSET A\$ = expression

A statement that assigns data in the expression to A\$.

RUN filespec[,R] [line number]

A command that loads and executes a program stored on disk (the R option causes the files to remain open) or executes the program currently in memory, optionally starting at the specified line number.

SAVE filespec[,A],P]

A command that saves the program currently in memory. The A option saves the program in ASCII format. The P option saves the program as a protected program.

SCREEN (X,Y[,n])

A function that returns the ASCII code that represents the character at the location X,Y. If *n* is specified, the color attribute of the character is returned instead.

SCREEN graphics mode, video mode

A statement that sets screen attributes on or off. The graphics mode can be set to display Z-19 graphics, the video mode can be set to reverse video.

SGN(X)

A function that returns the sign of X.

SHELL [command]

A statement that allows another program to be executed (from DOS). GW-BASIC only.

SIN(X)

A function that returns the sine of X, which must be expressed in radians.

SPACE\$(nn)

A function that returns a string of *nn* spaces.

SPC(nn)

A function that returns *nn* blanks (to be printed).

SQR(X)

A function that returns the square root of X, which must be greater than or equal to zero.

STOP

A statement that halts program execution. Program execution may be continued with the CONT command.

STR\$(X)

A function that returns the string representation of X.

STRING\$(nn,X|X\$)

A function that returns *nn* characters of the ASCII code X or X\$.

SWAP variable 1, variable 2

A statement that exchanges the values of variable 1 with the value of variable 2. The two variables must be of the same type.

SYSTEM

A command that returns control to MS-DOS (the operating system).

TAB(nn)

A function that positions the cursor or print head to the column *nn* when used with PRINT or LPRINT.

TAN(X)

A function that returns the tangent of X, which must be in radians.

THEN...

A part of the IF ... THEN ... ELSE statement, a conditional branch and/or execution statement.

TIME

A function that returns the number of seconds that have elapsed since the current date started (midnight). Z-BASIC only.

TIMER

A function that returns the number of seconds that have elapsed since the current date started (midnight). GW-BASIC only.

TIMER ON|OFF|STOP

A statement that enables or disables timer event trapping (GW-BASIC only).

TIME\$[= X\$]

A statement that sets or retrieves the current system time.

TRON

A command that turns the program tracer on.

TROFF

A command that turns the program tracer off.

USR[n](arguments)

A function that calls a machine language routine.

VAL(X\$)

A function that returns the numeric value of X\$.

VARPTR(variable |file number)

A function that returns the memory location of the specified variable or file buffer.

VARPTR\$(variable)

A function that returns the memory location of the specified variable as a three-byte string (GW-BASIC only).

VIEW([[SCREEN]](X1,Y1)-(X2,Y2)[,[color]][,[border]]])

A statement that sets the parameters of a viewport, to which window contents will be mapped (GW-BASIC only).

VIEW PRINT [top screen line TO bottom screen line]

A statement that sets the text screen area (GW-BASIC only).

WAIT port,X,Y

A statement that suspends program execution until the input port meets the specified parameters.

WEND

The end statement for a WHILE ... WEND loop.

WHILE ... WEND

Statements that set the parameters and boundaries of a program loop.

WIDTH [device,|file number,]nn

A statement that sets the limit to *nn* (columns) of a device. The only recognized device in Z-BASIC is LPRINT. GW-BASIC recognizes LPT1:, COM1:, and files.

WINDOW [[SCREEN]](X1,Y1)-(X2,Y2)

A statement that sets the coordinates of the screen (referred to as world coordinates). GW-BASIC only.

WRITE [expression][,|; expression]

A statement that sends data to the screen.

WRITE #n,X

A statement that send data to a sequential file.

System Configuration

The Z-100 Computer may be connected to many different types of printers, modems, and other devices which make use of either a Centronics-type parallel signal or RS-232 serial signals. This appendix will show you how to use the MS-DOS CONFIGUR utility to make your computer ready for use with different devices.

CONFIGUR will guide you through each phase of selecting the necessary operating conditions for your computer when it is used with printers, modems, and disk drives. If you are configuring a printer, you will need to determine the type of interface (parallel or serial) being used by the printer. The printers and other devices supported directly by CONFIGUR are listed in Table F-1.

Table F-1: Devices Directly Supported by CONFIGUR

PARALLEL OR SERIAL	DEVICE NAME AND MODEL	COMMUNICATIONS PROTOCOL
Parallel ¹	Diablo 930	Centronics-type parallel interface.
Parallel	Epson MX-80	Centronics-type parallel interface.
Serial	QUME Sprint 11	4800 baud, DTR positive (pin 20).
Serial	Epson MX-80	4800 baud, DTR positive (pin 20).
Serial	Heath H-25 and H-125	4800 baud, RTS positive (pin 4).
Serial	Zenith Z-25 and Z-1 25	4800 baud, RTS positive (pin 4).
Serial	Heath H-14 and WH-24	4800 baud, RTS negative (pin 4).
Serial	Diablo 630	1200 baud, ETX/ACK.
Serial	Diablo 1640	1200 baud, ETX/ACK.
Serial	Diablo 620	300 baud, ETX/ACK.
Serial	Heath/Zenith WH-23 modem	300 baud, no handshaking.
Serial	Heath/Zenith WH-33 modem	300 baud, no handshaking.
Serial	Heath/Zenith WH-34 modem	300 baud, no handshaking.
Serial	Heath/Zenith WH-1 2 Votrax Type-N-Talk	4800 baud, RTS positive (pin 4).

1. Most devices that use a Centronics-type parallel interface are supported by this configuration without further modification. However, some parallel devices not sold by Zenith Data Systems may require special communications protocol not supported by the Z-100.

If your peripheral is not listed in the table, you will need to determine whether it can be configured to match one of the devices listed. Otherwise, you will need to determine the type of interface (parallel or serial) you will be using and if you are using a peripheral that requires serial communications, you will need to know the baud rate, parity status, number of stop bits, word length, and handshaking information.

NOTE: Some peripherals (not sold by Zenith Data Systems Corporation or Heath Company) may require making a custom cable for proper operation.

The CONFIGUR Utility

The CONFIGUR utility that is included with Zenith Data Systems' MS-DOS version 2 for the Z-100 makes use of a number of menus and displays. This appendix has been laid out by display screen, with appropriate instructions to guide you to the next screen according to each selection you make.

To use the CONFIGUR utility, enter the following command line.

```
CONFIGUR
```

Press the **RETURN** key. Your computer's screen will clear and then show a display similar to Display 1. Proceed to Display 1.

Display 1

CONFIGUR version 2.20
Copyright(C) 1984 Zenith Data Systems Corporation

Use one of the following options to configure a device.

Options	Current settings
A. Configure PRN device	(J1,4800,RTS Pos,1 Stop Bit,8 bit word)
B. Configure AUX device	(J2,9600,1 Stop Bit,8 bit word)
C. Configure CON device	(System CRT)
D. Configure Disk step rate	(A: = 30,B: = 30,C: = 15,D: = 15)
E. Exit with no changes	

Enter your selection (A-E):

The PRN device is the printer, which may require either serial or parallel signals; the AUX device is for serial communications, which may include a second printer or other peripheral; the CON device is the system console, including keyboard and display. Note that the CON device may be routed to a remote display or printing terminal, providing remote control of the computer. Likewise, you may configure the disk step rate, which is the speed that is allowed by the system for the disk drives to move the read/ write head from one track to the next.

You will also note the current configuration is shown opposite the devices. As it is shipped from the factory, MS-DOS is configured for a serial printer through J1 that communicates at 4800 baud, recognizes RTS positive handshaking, and works with 8-bit data words and 1 stop bit. The AUX device is configured to work at 9600 baud, no handshaking, 8-bit data words, and 1 stop bit. The CON device is the system keyboard and display. The disk drive step rates are set at 30 milliseconds for 5.25-inch disk drives and 15 milliseconds for 8-inch disk drives.

- To exit the program without making any changes to the way the operating system is configured, press the E key. The program will return control to MS-DOS (the MS-DOS prompt will be displayed on your screen).

- To configure the PRN (printer) device, press the A key and proceed to Display 2.
- To configure the AUX (auxiliary) input/output device, press the B key and proceed to Display 3.
- To configure the CON (console) device, press the C key and proceed to Display 4.
- To set the step rate of any or all disk drives, press the D key and proceed to Display 5.

Display 2

Use one of the following options to select the PRN device.

- A. Centronics, Diablo 630, or NIX-80 Parallel (Parallel)
- B. QUME Sprint 11/MX-80 Serial (Serial A(R), 4800 baud, DTR Pos. (pin 20))
- C. H/Z-25 (Serial A(R), 4800 baud, RTS Pos. (pin 4))
- D. H-14/WH-24 (Serial A(R), 4800 baud, RTS Neg. (pin 4))
- E. Diablo 630/1640 (Serial A(R), 1200 baud, ETX/ACK)
- F. Diablo 620 (Serial A(R), 300 baud, ETX/ACK)
- G. WH-23/WH-33/WH-43 modem (Serial A(R), 300 baud, No handshake)
- H. WH-12 Votrax Type-N-Talk (Serial A(R), 4800 baud, RTS Pos. (pin 4))
- I. System CRT
- J. User defined
- K. Exit with no changes

NOTE: Option G may require a special cable.

Enter selection (A-K):

- To select a Centronics-type parallel interface printer, such as those in option A, press the A key and proceed to Display 18.
- To select one of the serial printers represented in options B through F, press the appropriate key. Proceed to Display 19.

- To select a modem that communicates at 300 baud with no handshaking, press the G key. Proceed to Display 19.
- To select the Votrax Type-N-Talk speech synthesizer, press the H key. Proceed to Display 19.
- If you elect to use the system's display monitor for output, press the I key. Proceed to Display 9.
- If you do not want to make any changes, press the K key. Proceed to Display 8.
- If you wish to custom configure the PRN device, press the J key and proceed to Display 9.

Display 3

Use one of the following options to select the AUX device.

- A. Centronics, Diablo 630, or MX-80 Parallel (Parallel)
- B. QUME Sprint 11/MX-80 Serial (Serial B(J2), 4800 baud, DTR Pos. (pin 20))
- C. H/Z-25 (Serial B(J2), 4800 baud, RTS Pos. (pin 4))
- D. H-14/WH-24 (Serial B(J2), 4800 baud, RTS Neg. (pin 4))
- E. Diablo 630/1640 (Serial B(J2), 1200 baud, ETX/ACK)
- F. Diablo 620 (Serial A(J1), 300 baud, ETX/ACK)
- G. WH-23/WH-33/WH-43 modem (Serial B(J2), 300 baud, No handshake)
- H. WH-12 Votrax Type-N-Talk (Serial B(J2), 4800 baud, RTS Pos. (pin 4))
- I. System CRT
- J. User defined
- K. Exit with no changes

NOTE: Options A through F and H may require a special cable.
Enter selection (A-K):

- To select a Centronics-type parallel interface printer, such as those shown in option A, press the A key and proceed to Display 18.

- To select one of the serial printers represented in options B through F, press the appropriate key. Proceed to Display 20.
- To select a modem that communicates at 300 baud with no handshaking, press the G key. Proceed to Display 19.
- To select the Votrax Type-N-Talk speech synthesizer, press the H key. Proceed to Display 20.
- If you elect to use the system's display monitor for output, press the I key. Proceed to Display 9.
- If you do not want to make any changes, press the K key. Proceed to Display 8.
- If you wish to custom configure the AUX device, press the J key and proceed to Display 9.

Display 4

Use one of the following options to select the CON device.

- A. Centronics, Diablo 630, or MX-80 Parallel (Parallel)
- B. QUME Sprint 11/MX-80 Serial (Serial A(R), 4800 baud, DTR Pos. (pin 20))
- C. H/Z-25 (Serial A(R), 4800 baud, RTS Pos. (pin 4))
- D. H-14/WH-24 (Serial A(R), 4800 baud, RTS Neg. (pin 4))
- E. Diablo 630/1640 (Serial A(J), 1200 baud, ETX/ACK)
- F. Diablo 620 (Serial A(R), 300 baud, ETX/ACK)
- G. WH-23/WH-33/WH-43 modem (Serial A(R), 300 baud, No handshake)
- H. WH-12 Votrax Type-N-Talk (Serial A(R), 4800 baud, RTS Pos. (pin 4))
- I. System CRT
- J. User defined

- K. Exit with no changes

NOTE: Option G may require a special cable.

Enter selection (A-K):

- To select a Centronics-type parallel interface printer, such as those shown in option A, press the A key and proceed to Display 18.
- To select one of the serial printers represented in options B through F, press the appropriate key. Proceed to Display 19.
- To select a modem that communicates at 300 baud with no handshaking, press the G key. Proceed to Display 19.
- To select the Votrax Type-N-Talk speech synthesizer, press the H key. Proceed to Display 19.
- If you elect to use the system's display monitor for output, press the I key. Proceed to Display 9.
- If you do not want to make any changes, press the K key. Proceed to Display 8.
- If you wish to custom configure the CON device, press the J key and proceed to Display 9.

Display 5

Select which Disk Drive you wish to Display/Alter

- A. Display/Alter step rate for drive A:**
- B. Display/Alter step rate for drive B:**
- C. Display/Alter step rate for drive C:**
- D. Display/Alter step rate for drive D:**
- E. Exit back to main menu**

Enter selection (A-E):

- To display and/or alter the step rate of the 5.25-inch floppy disk drive, drive A, press the A key and proceed to Display 6.
- To display and/or alter the step rate of the 5.25-inch floppy disk drive, drive B, press the B key. Display 6 is similar to the display you will see. Follow the directions given with Display 6.

- To display and/or alter the step rate of the 8-inch floppy disk drive, drive C, press the C key and proceed to Display 7.
- To display and/or alter the step rate of the 8-inch floppy disk drive, drive D, press the D key and follow the directions given with Display 7.
- If you do not want to display or alter the step rate of any of the floppy disk drives that are supported by MS-DOS, press the E key and proceed to Display 8.

Display 6

Drive A: Step rate is currently 30mS. Select new step rate.

A. 6 mS

B. 12 mS C. 20 mS D. 30 mS

E. No change

Enter selection (A-E):

- The 5.25-inch, 48-tpi, double-sided, double-density floppy disk drives supplied by Zenith Data Systems will handle a step rate of 6 milliseconds.
- To select a 6 millisecond step rate, press the A key and proceed to Display 5.
- To select a 12 millisecond step rate, press the B key and proceed to Display 5.
- To select a 20 millisecond step rate, press the C key and proceed to Display 5.

- To select a 30 millisecond step rate, press the D key and proceed to Display 5.
- If you do not want to change the current step rate, press the E key and proceed to Display 5. 5.

Display 7

Drive C: Step rate is currently 15mS. Select new step rate.

- A. 3 mS**
- B. 6 mS C. 10 MS D. 15 mS**
- E. No change**

Enter selection (A-E):

The 8-inch, 48-tpi, double-sided, double-density floppy disk drives supplied by Zenith Data Systems will handle a step rate of 3 milliseconds.

- To select a 3 millisecond step rate, press the A key and proceed to Display 5.
- To select a 6 millisecond step rate, press the B key and proceed to Display 5.
- To select a 10 millisecond step rate, press the C key and proceed to Display 5.
- To select a 15 millisecond step rate, press the D key and proceed to Display 5.
- If you do not want to change the current step rate, press the E key and proceed to Display 5.

Display 8

CONFIGUR version 2.20
Copyright(C) 1984 Zenith Data Systems Corporation

Use one of the following options to configure a device.

Options	Current settings
A. Configure PRN device	(J1,4800,RTS Pos,1 Stop Bit,8 bit word)
B. Configure AUX device	(J2,9600,1 Stop Bit,8 bit word)
C. Configure CON device	(System CRT)
D. Configure Disk step rate	(A: = 30,B: = 30,C: = 15,D: = 15)

Use the following options to modify an existing system.

- E. Exit program
- F. Make changes to disk
- G. Make changes to memory
- H. Make changes to both disk and memory

Enter your selection (A-H):

This display will allow you to make your selections final or make further changes to the system configuration.

- To exit the program without making any changes to the way the operating system is configured, press the E key. The program will return control to MS-DOS (the MS-DOS prompt will be displayed on your screen).
- To configure the PRN (printer) device, press the A key and proceed to Display 2.
- To configure the AUX (auxiliary) input/output device, press the B key and proceed to Display 3.
- To configure the CON (console) device, press the C key and proceed to Display 4.

- To set the step rate of any or all disk drives, press the D key and proceed to Display 5.
- To configure the operation system in memory only, press the G key. The system in memory will be modified according to your instructions. The screen will clear and once again show Display 8.
- To configure the operating system on the disk only, press the F key; or on the disk and in memory, press the H key. The screen will display the following prompt.

Enter drive name with system to modify (A-H):

- Press the key that corresponds to the drive which contains the disk to be modified. The drive access indicator will come on and when the disk has been modified, the screen will clear and once again show Display 8.

Display 9

- A. System CRT**
- B. Serial device**
- C. Parallel device**

Enter your device type:

- If you want to use your computer's monitor for output, press the A key and proceed to Display 10. Remember that you are selecting the computer's monitor.
- If you want to use a serial device, press the B key and proceed to Display 10. Remember that you are selecting a serial device.
- If you want to use a parallel device, press the C key and proceed to Display 10. Remember that you are selecting a parallel device.

Display 10

Answer the following questions with Y for Yes and N for No.

Strip parity on input? (Y/N) <N>

Parity checking is used throughout your computer. If you do not want parity checking on input, press either the N key or the **RETURN** key. Otherwise, press the Y key. The computer will now display the following line.

Strip parity on output? (Y/N) <N>

Usually your answer for this question will be the same as for the previous one. After you press the appropriate key, the computer will display the following line.

Map lowercase to uppercase on input? (Y/N) <N>

Some software and devices are incapable of utilizing lowercase characters. This question gives you the opportunity to change all lowercase coming into the system to uppercase automatically. If you want lowercase characters converted to uppercase, press the Y key. Otherwise, press the N key or the **RETURN** key. The computer will display the following line.

Map lowercase to uppercase on output? (Y/N) <N>

This gives you the ability to convert lowercase characters to uppercase characters before they are transmitted. Press the Y key if you want to do this. Otherwise, press the N key or the **RETURN** key.

- Proceed to Display 11 if you selected the system CRT or parallel device at Display 9.
- Proceed to Display 12 if you selected a serial device at Display 9.

Display 11

If you do not wish a pad character, simply press the RETURN key, and then enter a zero as the number of pad character; otherwise press the actual key character you wish to pad.

For example, to pad after all line feeds, press the key marked LINE FEED.

Press the key corresponding to your desired pad characters:

Pad characters are added to allow extra time for a device to respond to a command. For instance, blank characters (pad characters) are sent following a line feed to allow a printer to properly position its print head to the beginning of the next line. Not all devices require pad characters. Refer to your printer's documentation.

- To use this feature, press the key which corresponds to the character which precedes the required pad characters. In most characters, this will be the line feed (LF) or RETURN (CR) key.
- If you do not need or want to use this feature, press the **RETURN** key.

The computer will display the following.

Enter the number of pad characters to send (0-255):

- Enter a number between 0 and 255 which corresponds to the number of characters that must be transmitted and press the **RETURN** key.
- If you are not using this feature, press the 0 key and then the **RETURN** key.
- Proceed as follows:

<u>If you selected:</u>	<u>Proceed to:</u>
System CRT	Display 8
Serial port A	Display 19
Serial port B	Display 20
Parallel device	Display 18

Display 12

Select one of the following I/O ports.

- A. Serial A(J1) (E8H)
- B. Serial B(J2) (ECH)

Enter your port selection:

The choice you make here will determine which connector on the back of the computer you will use.

- If you want to use port E8 hexadecimal, which is connector J1, press the A key.
- If you want to use port EC hexadecimal, which is connector J2, press the B key.
- Proceed to Display 13.

Display 13

Select one of the following baud rates.

- | | |
|----------|----------|
| A. 45.5 | I. 1200 |
| B. 50 | J. 1800 |
| C. 75 | K. 2000 |
| D. 110 | L. 2400 |
| E. 134.5 | M. 4800 |
| F. 150 | N. 9600 |
| G. 300 | O. 19200 |
| H. 600 | P. 38400 |

Enter the baud rate selection:

- Press the key that corresponds to the baud rate you want and proceed to Display 14.

Display 14

Use the following to select a handshake protocol.

- A. No Handshaking
- B. ETX/ACK C. DC3/DC1
- D. RTS Positive (pin 4)
- E. RTS Negative (pin 4)
- F. DTR Positive (pin 20)
- G. DTR Negative (pin 20)

Enter one of the handshake values:

Handshaking is a way for a serial device to signal the computer that it is ready or not ready to receive information. This option allows you to select the handshaking method that you need for your device. Select choice C for XON/XOFF operation.

- Press the key that corresponds to the handshaking method your device uses and proceed to Display 15.

Display 15

Use one of the following stop bit values.

- A. 1 Stop bit
- B. 1.5 Stop bits
- C. 2 Stop bits

Enter one of the stop bit values:

- Press the key that corresponds to the number of stop bits your serial device will use. The computer will display the following.

Do you wish to use parity? (Y/N) <N>

- If you do not want to use parity checking, press the N or press the **RETURN** key and proceed to Display 17.
- If you want to use parity checking, press the Y key and proceed to Display 16.

Display 16

Use one of the following parity selections.

- A.. Odd parity
- B. Even parity

Enter one of the parity values:

- If you are using odd parity, press the A key.
- If you are using even parity, press the B key.
- Proceed to Display 17.

Display 17

Use one of the following word length selections.

NOTE: Word length is exclusive of stop bits and parity.

- A 5 bit words**
- B. 6 bit words**
- C. 7 bit words**
- D. 8 bit words**

Enter one of the word length values:

- Press the key that corresponds to the number of bits each character will use. Proceed to Display 11.

Display 18

This display illustrates the back panel of the Z-100. It instructs you to plug your parallel cable into J3. Press any key to continue and proceed to Display 8.

Display 19

This display illustrates the back panel of the Z-100. It instructs you to plug your serial cable into J1. Press any key to continue and proceed to Display 8.

Display 20

This display illustrates the back panel of the Z-100. It instructs you to plug your serial cable into J2. Press any key to continue and proceed to Display 8.

Printer Configuration

Many of the printers that can be connected to your computer have switches that can be used to adapt the printer to different computers. This flexibility can make it appear that the printer or computer is malfunctioning when, in fact, both are operating correctly.

In order to simplify printer and computer configuration, you should first consult your printer's documentation and configure it to match the operating characteristics of one of the printers listed in Table F-1 and then use the CONFIGUR utility to match the computer to the printer you selected. If the printer cannot be matched with one of the printers listed in the table, or if you want to use other operating characteristics (perhaps to improve performance while being used as a serial device) then you should first configure the printer and then match the characteristics you have selected with the User-defined option of the CONFIGUR utility.

To configure your printer, consult the printer's documentation for setting the proper switches. Then, after you have set the printer, run the MS-DOS configuration utility to set the computer output characteristics to match that which you have selected for your printer.

Changing Hardware Configuration

Your computer may be configured a number of ways by changing internal switches and jumpers. The information presented in this appendix will allow you to custom configure your computer to your needs.

NOTE: You will need to open the cabinet and disassemble the computer. You may want to consult and have your ZDS dealer make the changes for you. Otherwise, you may use the instructions in this appendix to disassemble your computer, make the changes, and then reassemble your computer.

Disassembly

CAUTION: If your computer has a Winchester Disk Drive installed in it, run the Winchester SHIP utility **before** you start to disassemble your computer. Refer to your Winchester documentation for instructions.

WARNING: Before you remove the cabinet of your computer, turn it off and unplug it from the AC power source. There are hazardous voltages inside the cabinet with the power cord plugged into the wall.

To disassemble your computer, proceed to either All-in-One Model or LowProfile Model.

All-in-One Model

- ❑ Unplug the line cord from the AC power source.
- ❑ Refer to Figure G-1 and use a small, flat-blade screwdriver to move the metal slides all the way toward the front of the computer until they stop and then 1/4" toward the back of the computer as shown.
- ❑ Carefully lift the top portion of the cabinet straight up and set it to one side.
- ❑ At this point, you may remove the disk controller card to change the switch settings on the Z-207 disk controller card. The instructions for changing the switch settings are provided later in this section.

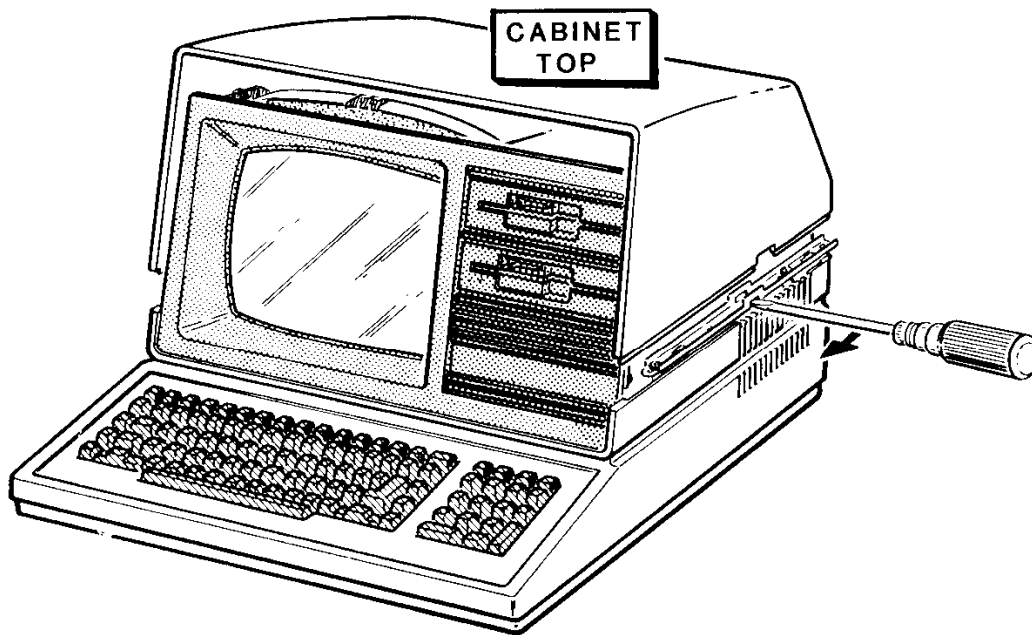

Figure G-1: All-in-One Cabinet Removal

- ❑ Refer to Figure G-2 and remove the back screws at positions A and B. These two screws hold the back of the slide in place.
- ❑ Pivot the back of each latching slide away from the computer as shown in the figure.
- ❑ Remove the five screws at positions C, D, E, F, and G. Your computer may or may not have ground straps at positions E and F. You will need to make sure these straps are reconnected during reassembly if they are present in your computer.
- ❑ Carefully lift the drive/video subassembly up and to the front of the computer about 4 or 5 inches; set it down gently in the forward position for the following steps.

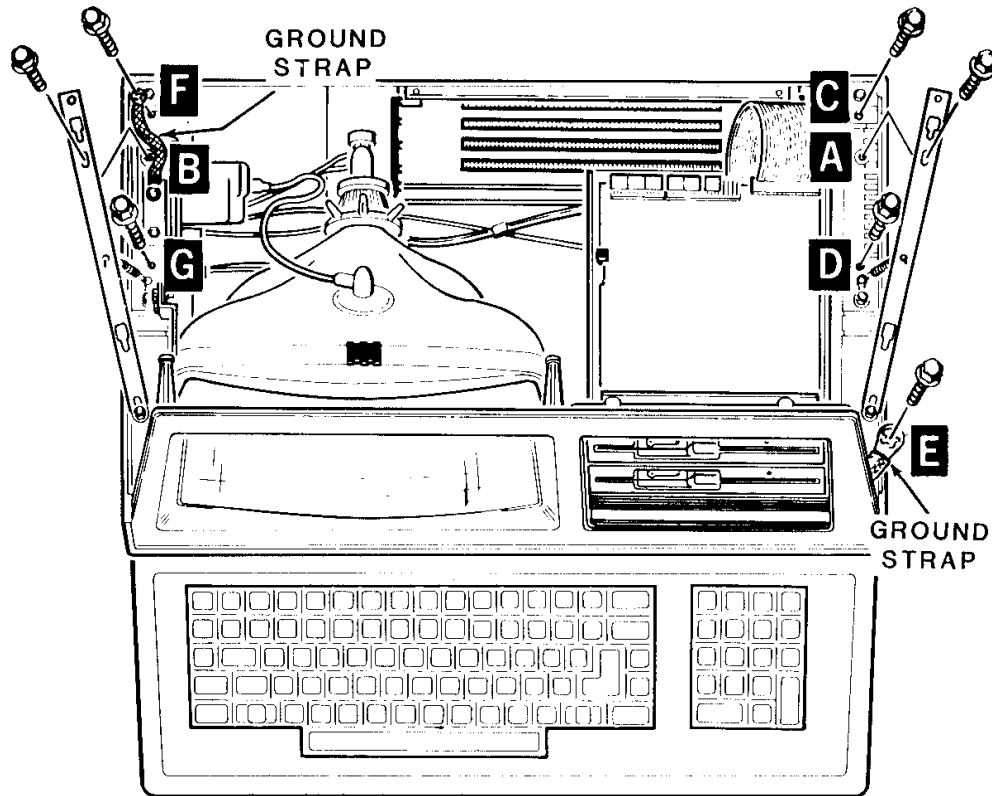

Figure G-2: Unfastening the Drive/Video Subassembly

- ❑ Refer to Figure G-3 and carefully unplug the signal/power cable from the video circuit board.
- ❑ Carefully unplug the flat cable from each disk drive as shown in the figure.
- ❑ Carefully unplug the power cables from each disk drive.

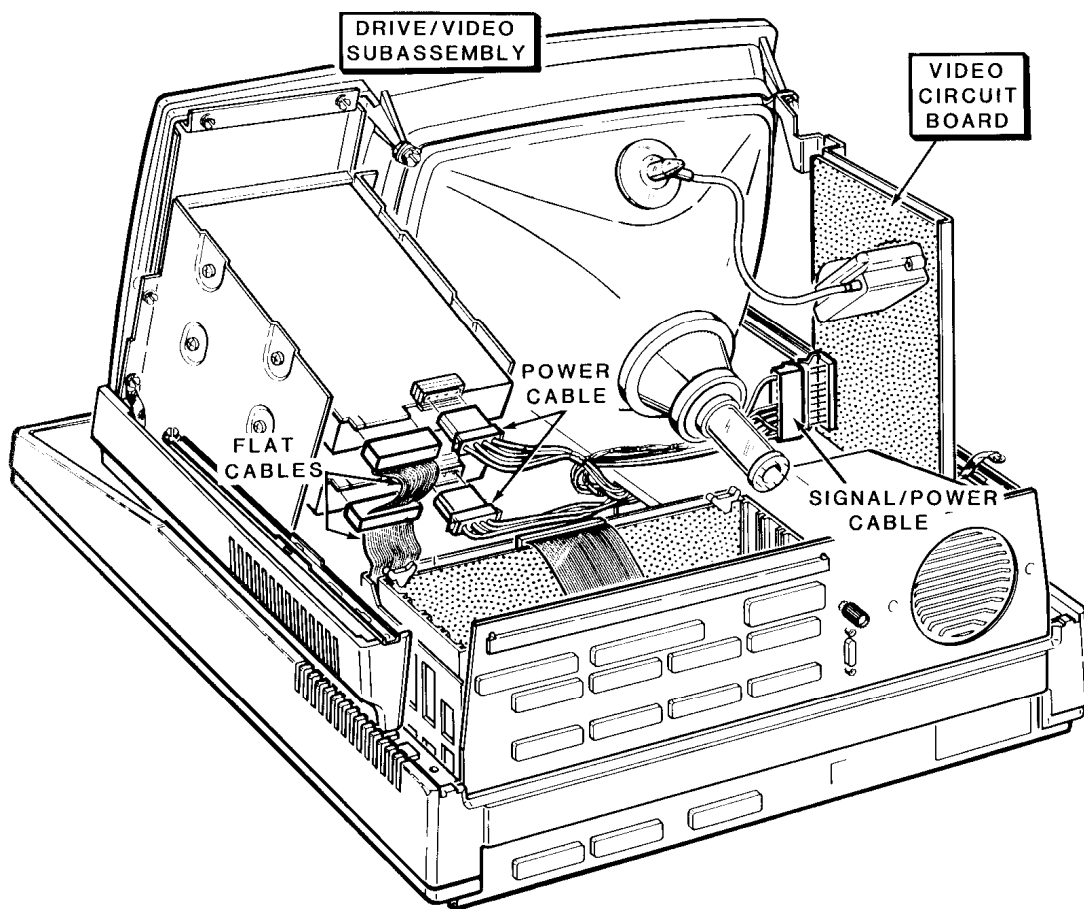

Figure G-3: Disconnecting the Floppy Disk Drives

- ❑ Remove the drive/video subassembly and set it carefully to one side.
- ❑ If your computer has a Winchester disk drive, refer to Figure G-4 and unplug cable 134-1279 and cable 134-1281 from the Winchester controller card.
- ❑ Unplug the power supply cable from the Winchester data separator board and the power supply cable from the Winchester disk drive.

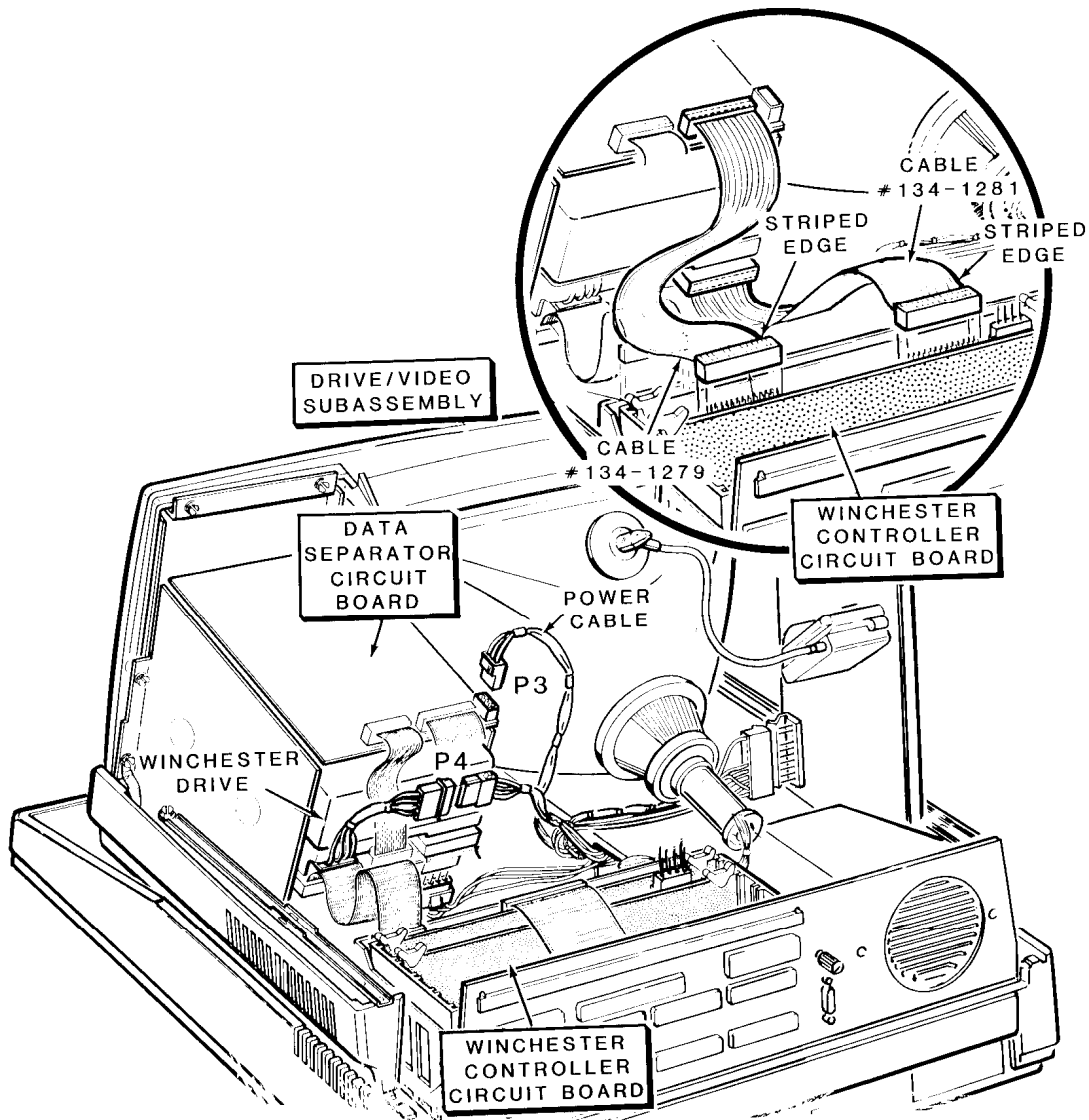

Figure G-4: Disconnecting the Winchester Disk System

- ❑ At this point, you may access switch S101 on the main board of the computer to change the switch settings. The instructions for changing the switch settings are provided later in this section.
- ❑ Proceed to Final Disassembly.

Low-Profile Model

- ❑ Unplug the line cord from the AC power source.
- ❑ Refer to Figure G-5 and inspect the back of each metal slide. If the shipping plugs (not illustrated) are still present, remove them by pulling them up, out of the back of each metal slide.
- ❑ Pull the metal slides all the way to the back of the computer. Then push them 1/4" to the front as illustrated in the figure.
- ❑ Carefully lift the top case straight up and set it to one side.
- ❑ At this point, you may remove the disk controller card to change the switch settings on the Z-207 disk controller card. The instructions for changing the switch settings are provided later in this section.

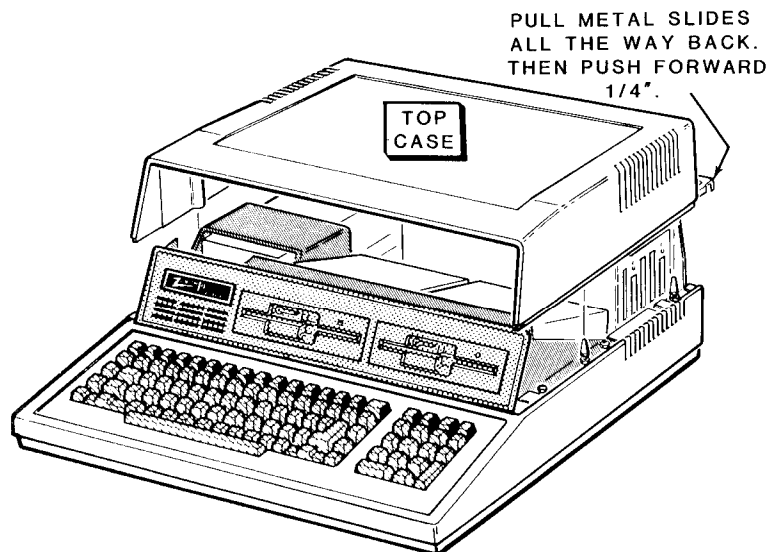

Figure G-5: Removing the Top Case

- ❑ Refer to Figure G-6 and remove the four screws at positions A, B, C, and D.
- ❑ Remove the two locking pins at E, and F.
- ❑ Carefully lift the drive subassembly up and to the front of the computer about 2 inches. Set it carefully back down in the forward position for the following steps.

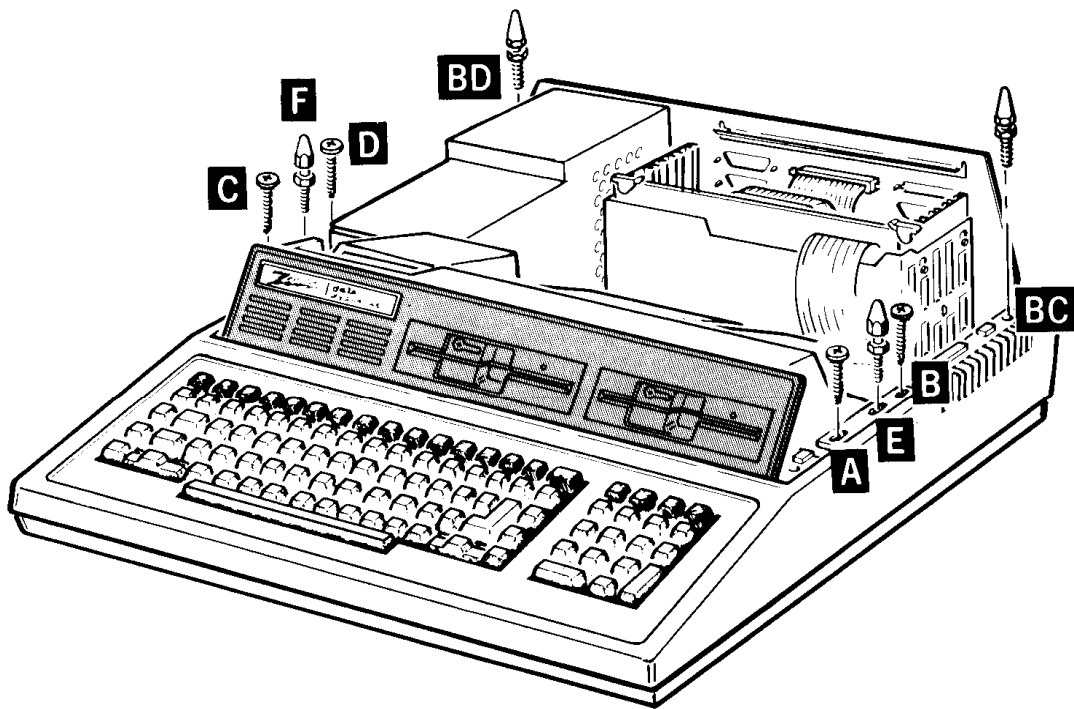

Figure G-6: Unfastening the Drive Subassembly

- ❑ Refer to Figure G-7 and carefully unplug the flat cable from each disk drive as shown.
- ❑ Carefully unplug the power cables from each disk drive.

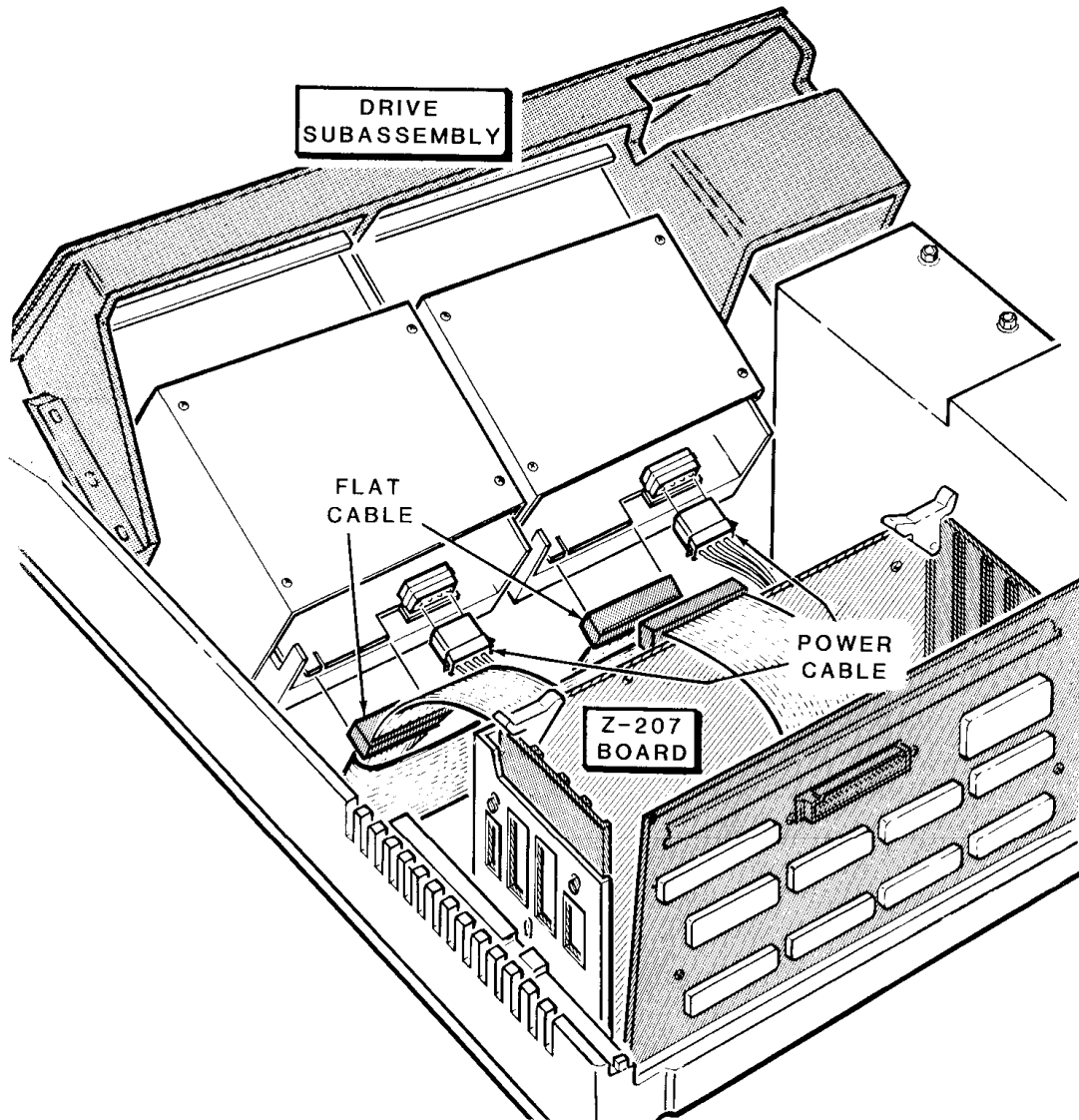

Figure G-7: Disconnecting the Floppy Disk Drives

- ❑ If your computer has a Winchester disk drive installed in it, refer to Figure G-8 and carefully unplug cable 134-1281 and cable 1341279 from the Winchester controller card.
- ❑ Unplug the power supply cable from the data separator board and the power supply cable from the Winchester disk drive.
- ❑ Remove the drive subassembly and carefully set it to one side.
- ❑ At this point, you may access switch S101 on the main board of the computer to change the switch settings. The instructions for changing the switch settings are provided later in this section.
- ❑ Proceed to Final Disassembly.

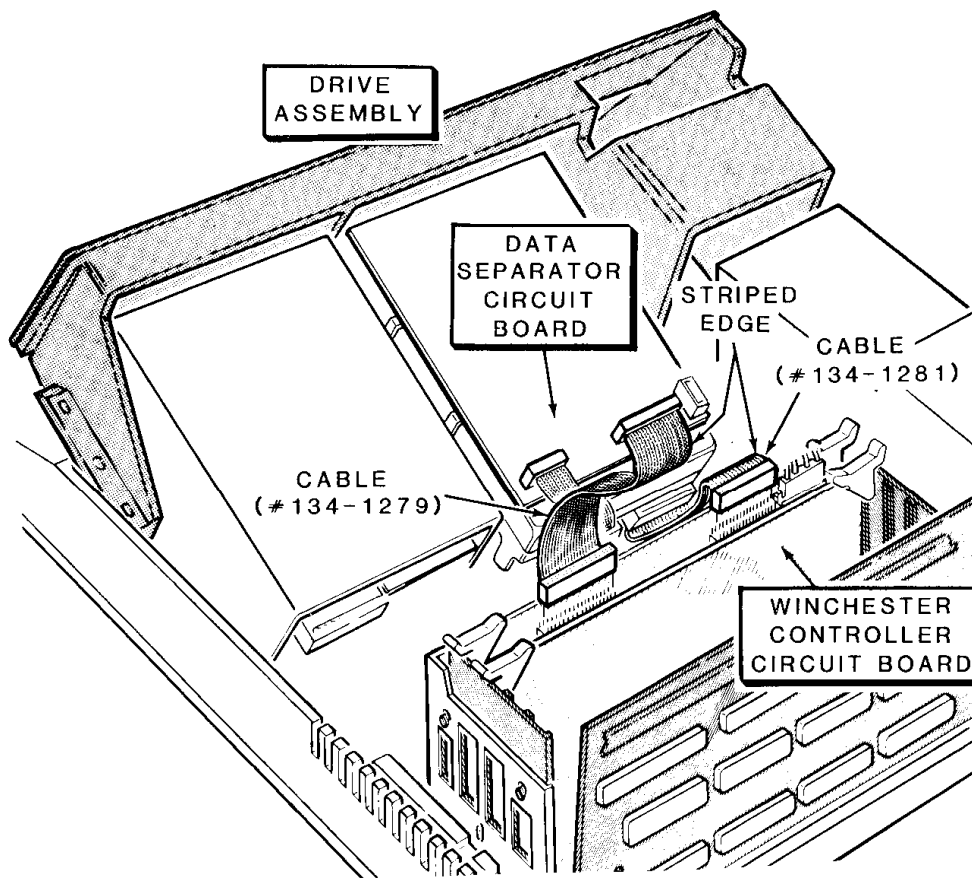

Figure G-8: Disconnecting the Winchester Disk Drive

Final Disassembly

- ❑ Refer to Figure G-9 and remove the two screws at positions **BA** and **BB** in the keyboard/base cover.
- ❑ If your computer is a Low-Profile model, remove the two locking pins at positions **BC** and **BD**. The All-in-One computer does not have these pins.
- ❑ Remove the keyboard/base cover by lifting it up and to the back of the computer to clear the covers, controls, and connectors on the back panel. Set the keyboard/base cover to one side.

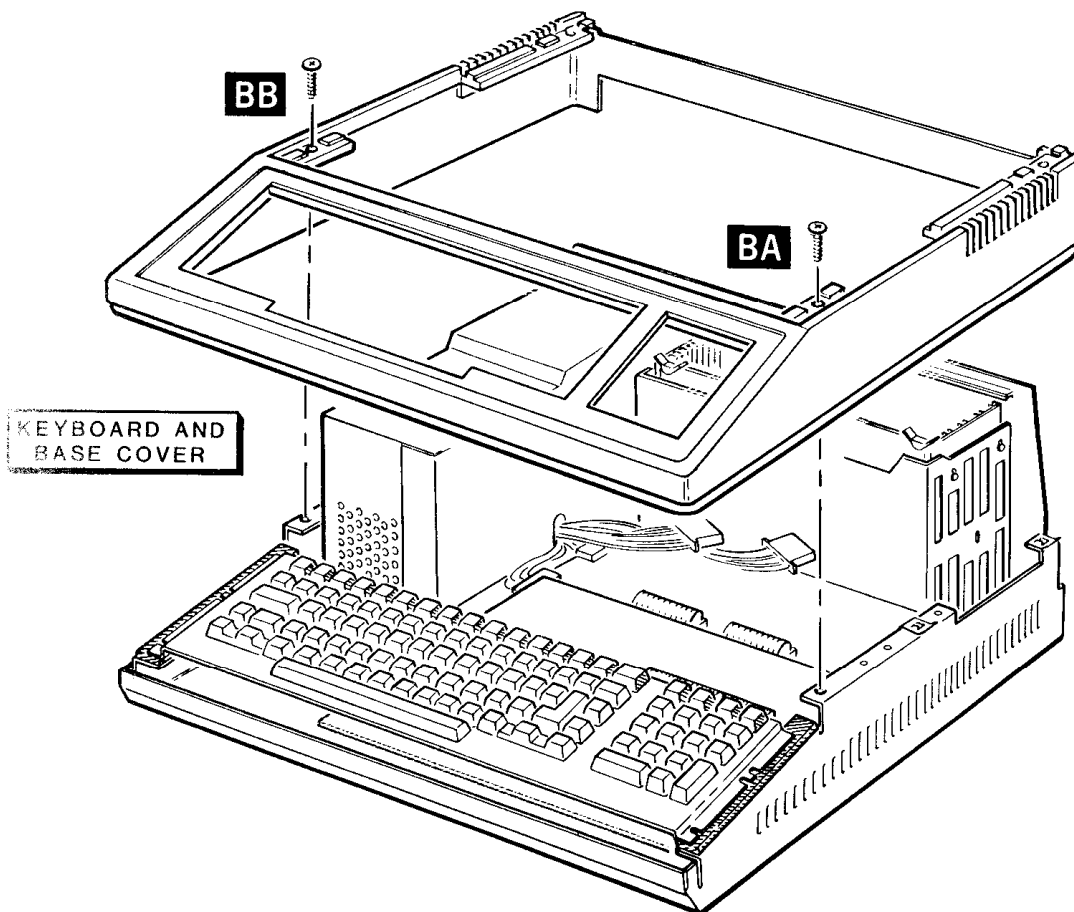

Figure G-9: Removing the Keyboard/Base Cover

- ❑ Refer to Figure G-10 and carefully lift the keyboard up and position it to the front of the computer.
- ❑ Carefully remove the three screws at positions **BE**, **BF**, and **BG** on the video board.
- ❑ At this point you can access the video board jumpers. The description of the settings of these jumpers are provided later in this appendix.
- ❑ If you are installing accessories in your computer, refer to the installation manual that accompany those accessories.

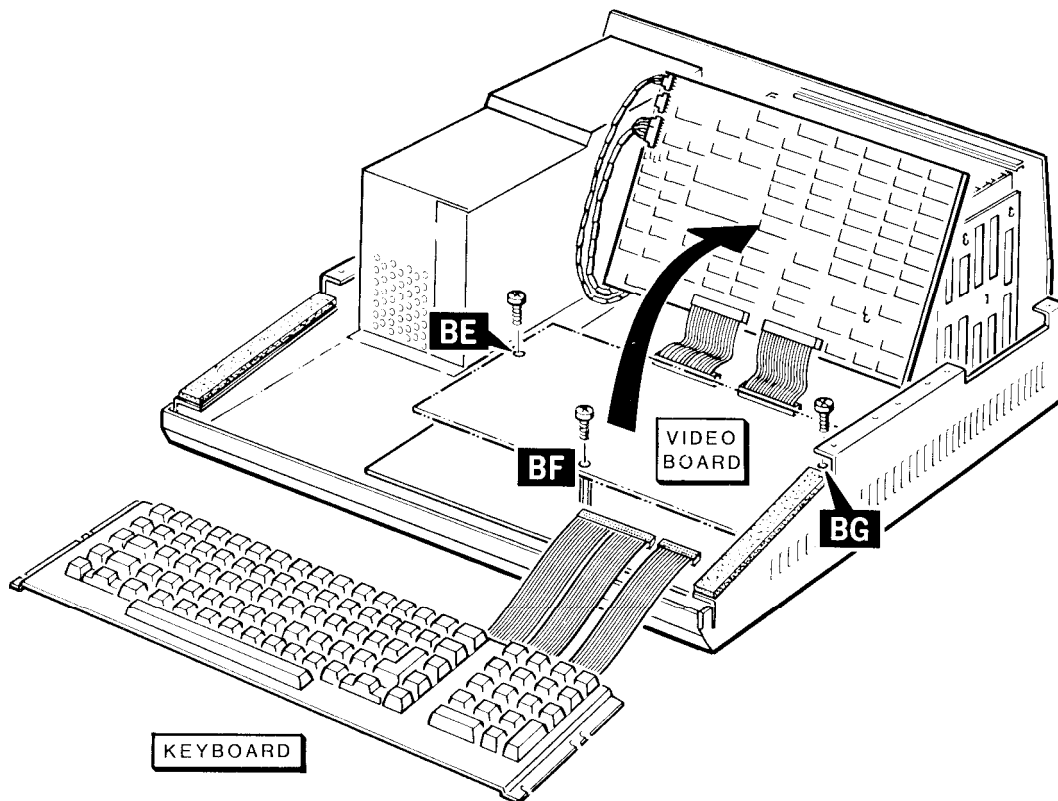

Figure G-10: Removing the Video Board

Reassembly

- ❑ Refer to Figure G-1 1 and reposition the video circuit board as shown in the figure.
- ❑ Install and tighten the three screws you removed during disassembly at positions **BE**, **BF**, and **BG**.

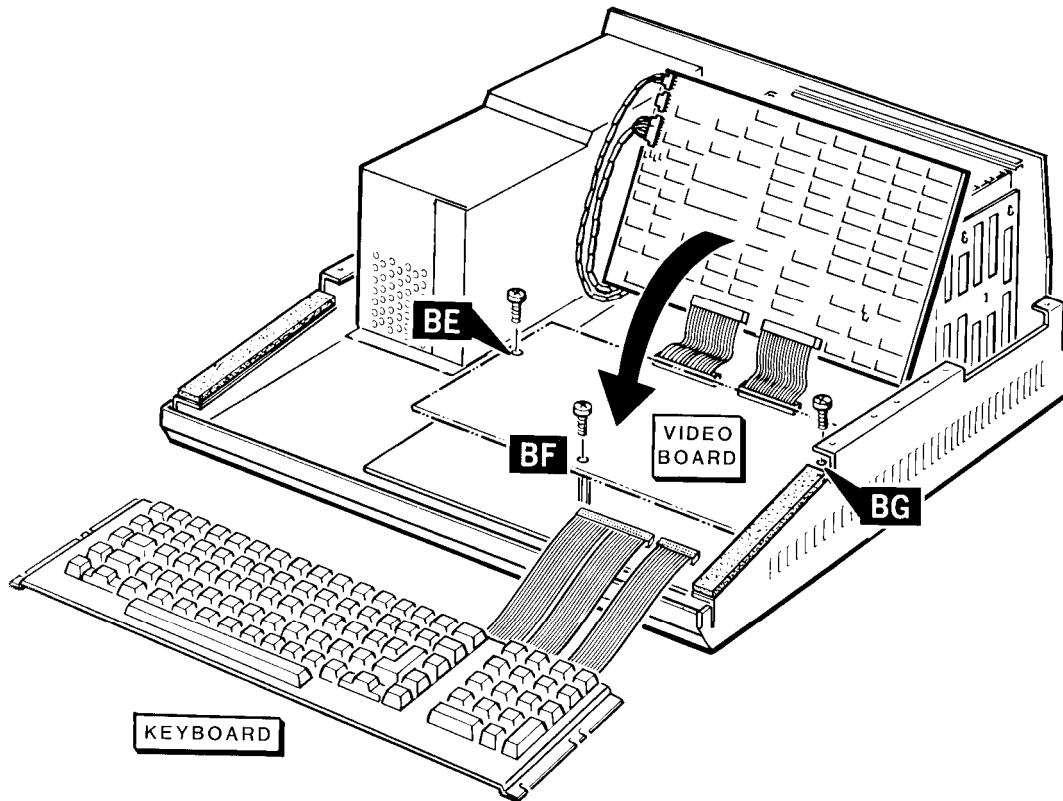

Figure G-11: Installing the Video Board

- ❑ Refer to Figure G-1 2 and position on the base.
- ❑ Lower the keyboard/base cover onto the base. Make sure the keys of the keyboard do not bind on the keyboard/base cover. The keyboard assembly can be shifted in one direction or another so that none of the keys bind.
- ❑ Install and tighten the two screws (you removed during disassembly) at positions **BA** and **BB**. Check to make sure the keys do not bind.
- ❑ If you have an All-in-One model, proceed to All-in-One Reassembly. If you have a Low-Profile model, proceed to Low-Profile Reassembly.

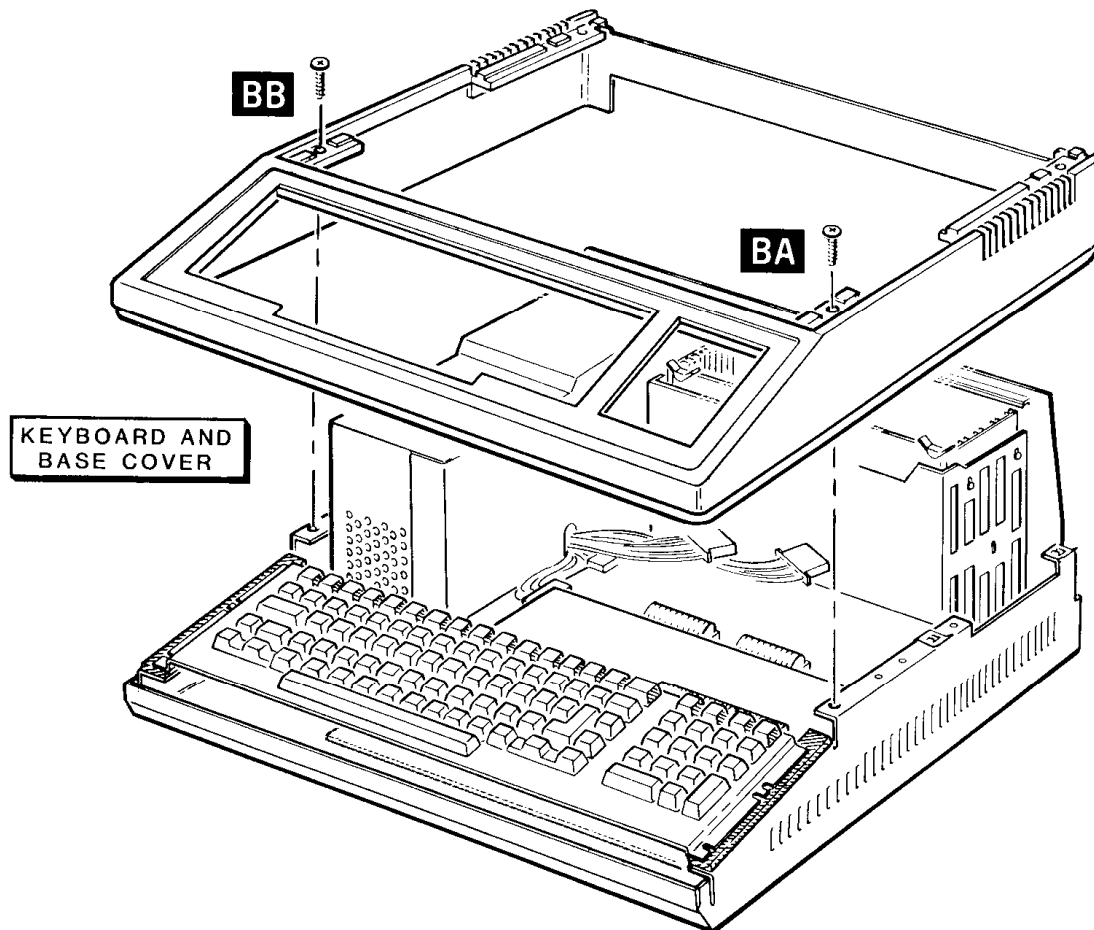

Figure G-12: Installing the Keyboard/Base Cover

All-in-One Reassembly

- ❑ Refer to Figure G-1 3 and carefully position the drive/video subassembly about 4 inches in front of its normal position on the base.
- ❑ Plug the signal/power cable onto its connector on the video driver board.
- ❑ Plug the power cables into each floppy disk drive.
- ❑ Position the small triangle (marked on the flat cable connector) or marked edge of the flat cable toward the outside (right side) of the computer.
- ❑ Plug the flat cable from the floppy disk controller card (Z-207 card) onto the disk drives as shown in the figure.

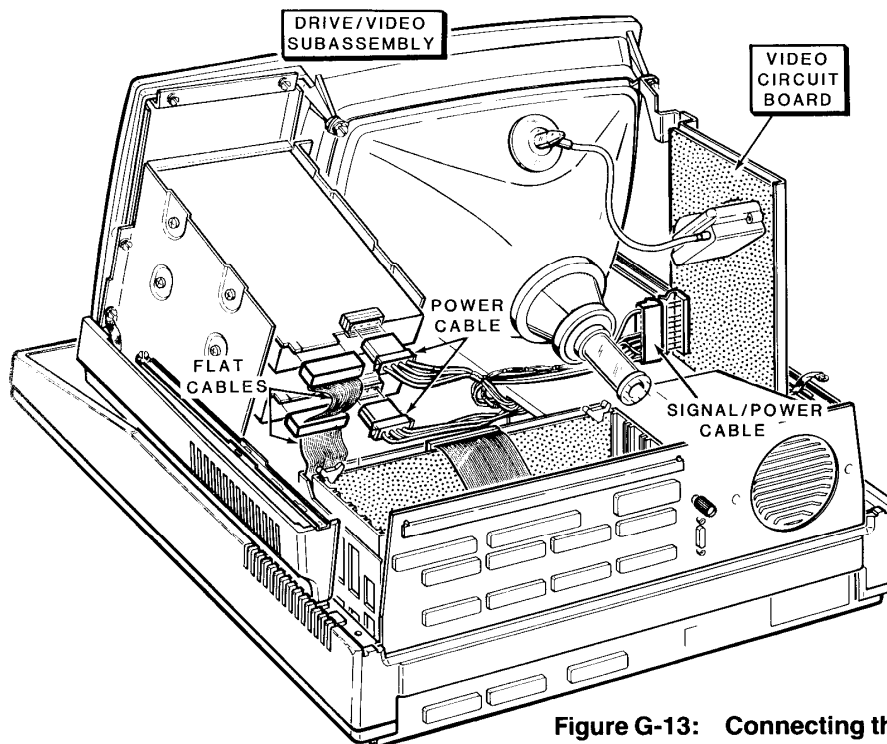

Figure G-13: Connecting the Signal/Power and Floppy Disk Drive Cables

- ❑ Refer to Figure G-14 and if you have a Winchester disk system, and plug the power supply cable into the Winchester disk drive.
- ❑ Plug the power supply cable into the data separator board.
- ❑ Plug cable 134-1279 (from the data separator board) into the Winchester controller card as shown in the figure.
- ❑ Plug cable 134-1281 (from the Winchester disk drive) into the Winchester controller card.

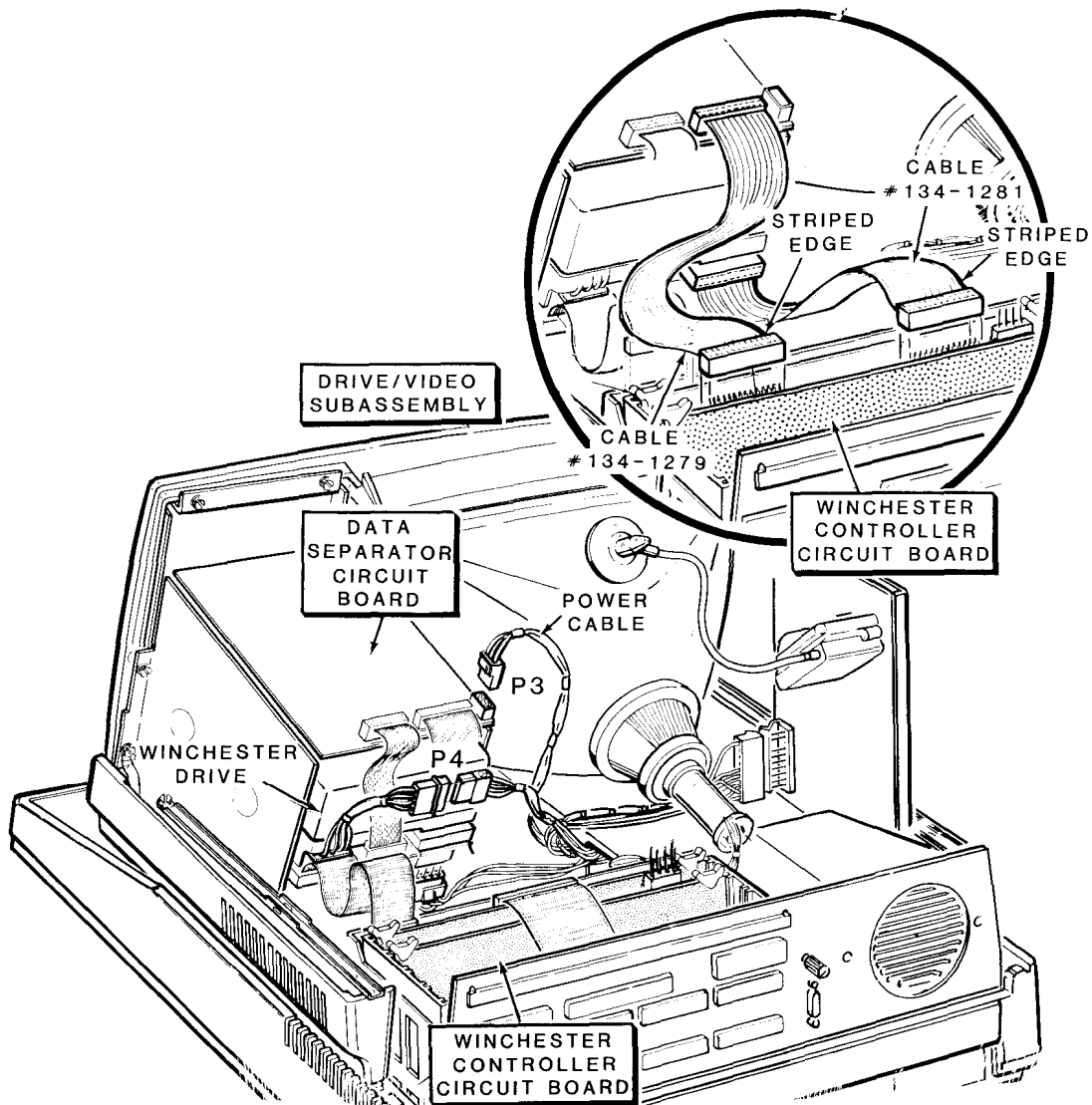

Figure G-14: Connecting the Winchester Disk Drive

- ❑ Move the drive/video subassembly to its normal position.
- ❑ Refer to Figure G-15 and install and tighten the five screws at positions **C**, **D**, **E**, **F**, and **G**. Fasten the ground straps if they are present (that were unfastened during disassembly) at positions **E** and **F**.
- ❑ Swing the latching slides back into their normal positions and replace the two screws at positions **A** and **B**. Make sure the slides move freely.

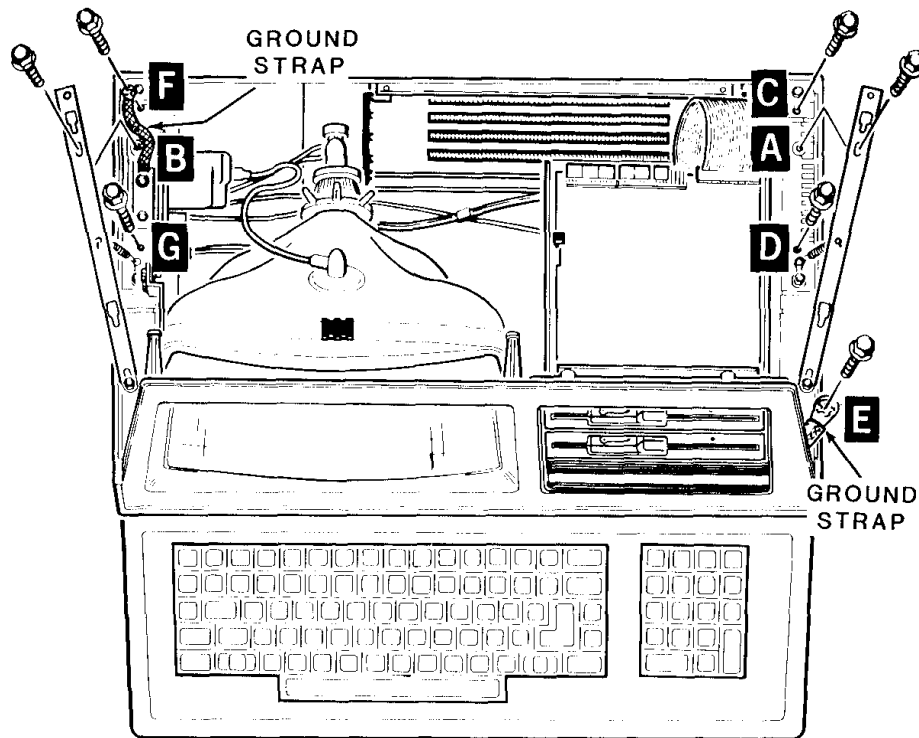

Figure G-15: Fastening the Drive/Video Subassembly to the Base

- Refer to Figure G-16. Replace the top portion of the cabinet by bringing it straight down into position. Use a small, flat-blade screwdriver and move the latches all the way to the front if they do not snap into place.

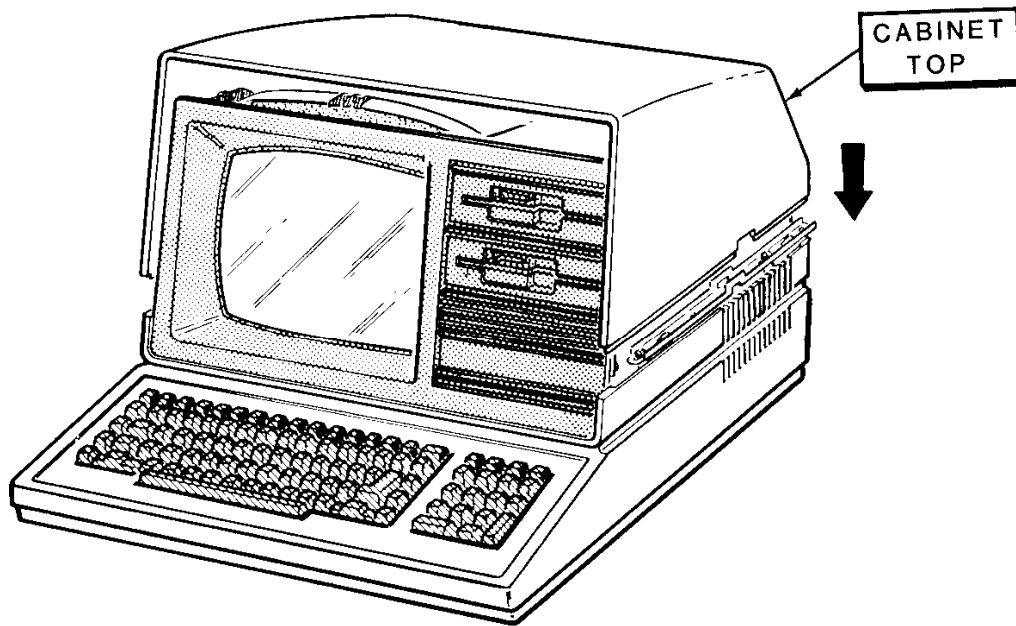

Figure G-16: Replacing the Cabinet Top

Low-Profile Model

- ❑ Refer to Figure G-1 7 and carefully place the drive subassembly about 2 inches to the front of its normal position on the base.
- ❑ Refer to the figure and inset #1. Plug the power cables into each of the floppy disk drives.
- ❑ Refer to the figure and inset #2. Position the small triangle (marked on the flat cable connector) or marked edge of the flat cable toward the outside (right side) of the computer.
- ❑ Plug the flat cable from the floppy disk controller card (Z-207 card) onto the disk drives as shown in the figure.

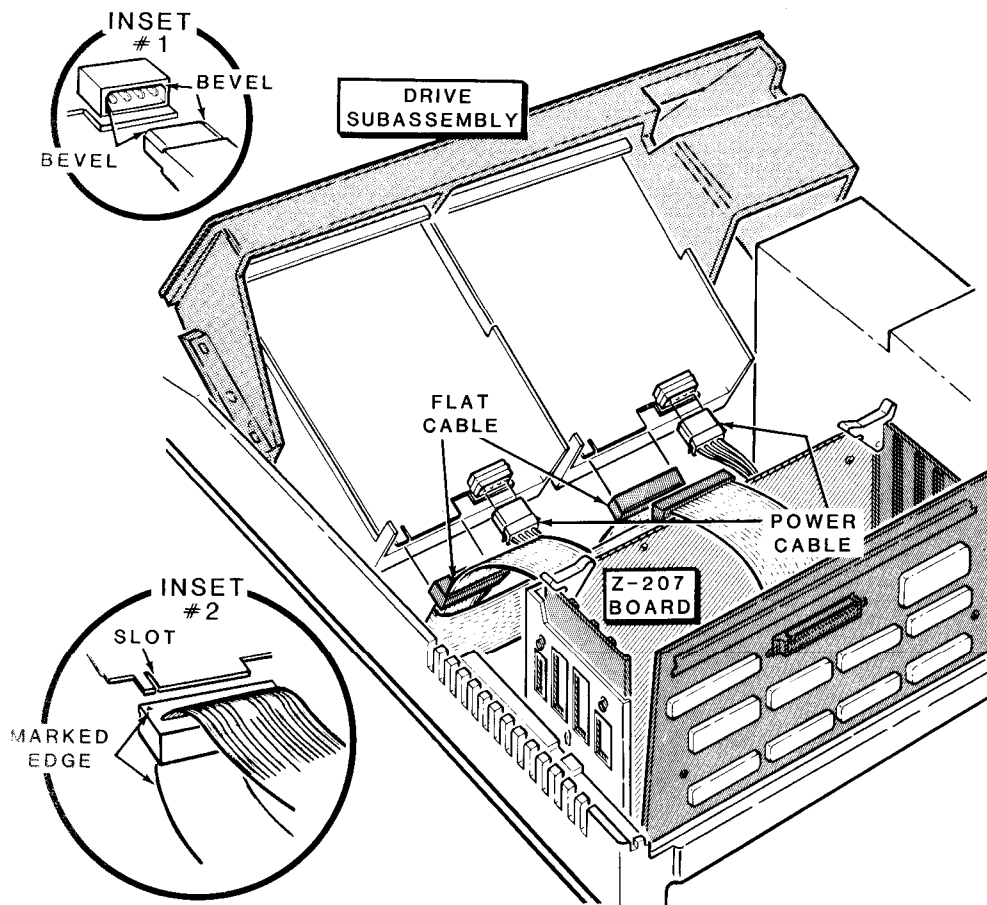

Figure G-17: Connecting the Floppy Disk Drive Cables

- ❑ Refer to Figure G-18 and if you have a Winchester disk system plug the power supply cable into the Winchester disk drive.
- ❑ Plug the power supply cable into the data separator board.
- ❑ Plug cable 134-1279 (from the data separator board) into the Winchester controller card as shown in the figure.
- ❑ Plug cable 134-1281 (from the Winchester disk drive) into the Winchester controller card.

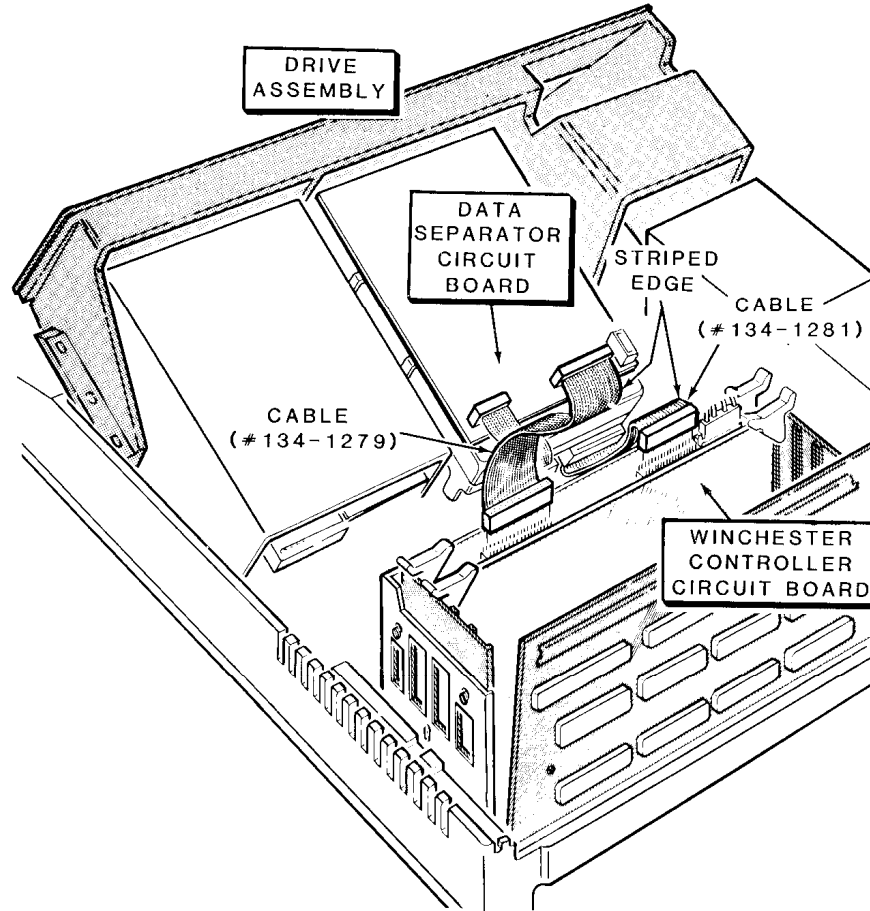

Figure G-18: Connecting the Winchester Disk Drive

- Move the drive subassembly to its normal position. Refer to Figure G-19.
- Install and tighten the two locking pins at positions **BC** and **BD**. Install and tighten the four screws at positions **A**, **B**, **C**, and **D**. Install and tighten the two locking pins at positions **E** and **F**.

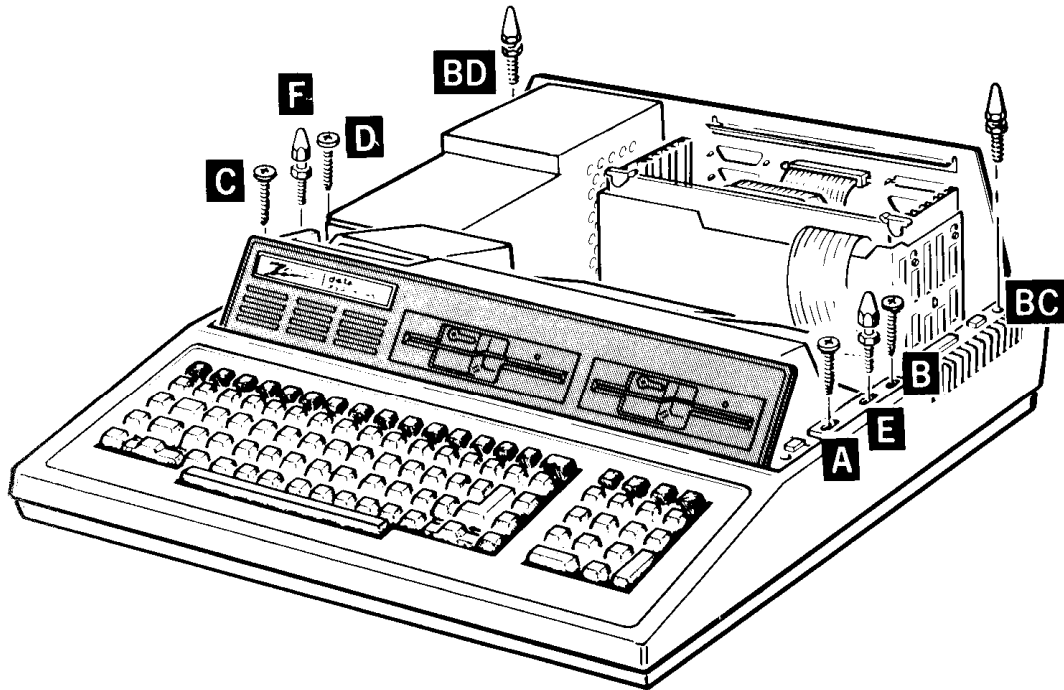

Figure G-19: Fastening the Drive Subassembly and Base

- Refer to Figure G-20. Replace the top case by bringing it straight down into its normal position. Push the latches all the way forward if they do not snap into place. If your computer had shipping inserts still installed in the latches, you do not need to reinstall them unless you are planning to ship your computer to another location.

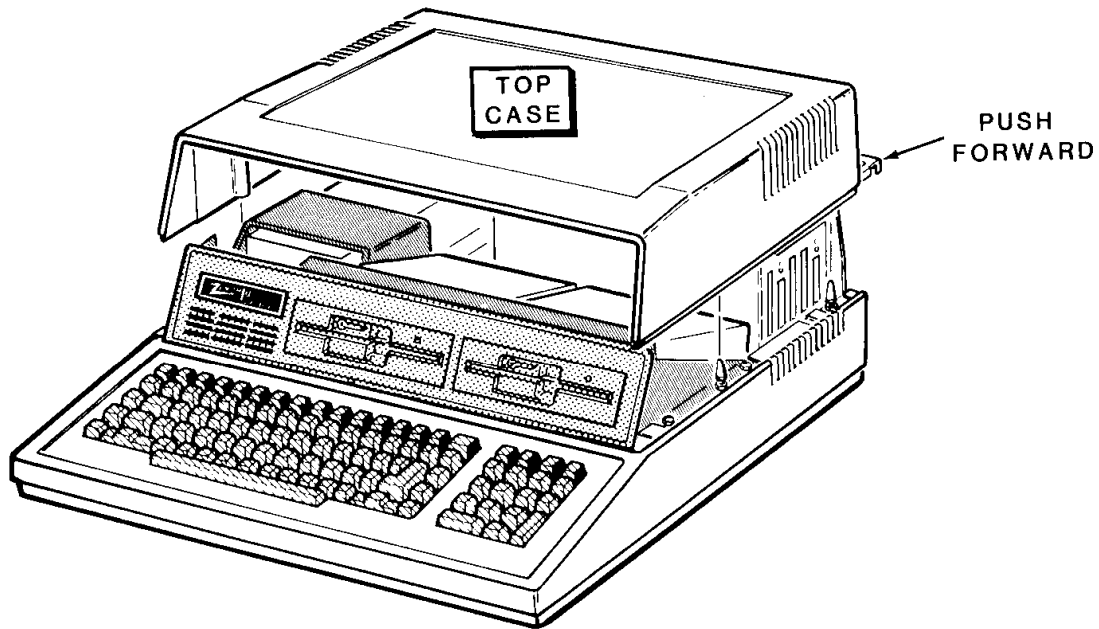

Figure G-20: Replacing the Cabinet Top

Switch S101

Switch S101 is located on the main board just in front of the card cage. To change any settings on the main switch you should remove the disk drive assembly. Once you have disassembled the computer to this point, refer to Figure G-21.

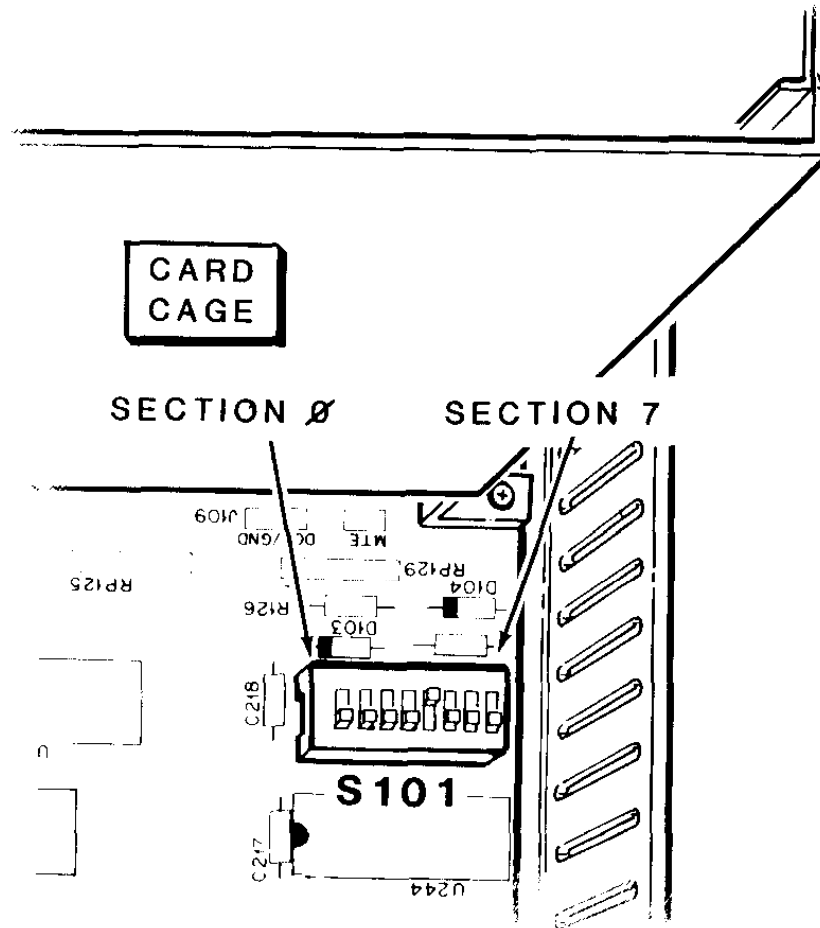

Figure G-21: Switch S101 (Main Board)

Although the sections of the switch are not marked on the main board itself, the positions should be counted (numbered) from left to right as shown in the figure. The ON side of the switch may be installed toward the front or back of the computer. The ON side will always indicate the ON position of the switch. Move the switch sections to the ON or OFF position as needed to configure your system. The sections are described in Table G-1.

Table G-1: S101 Switch Settings

<u>SECTION</u>	<u>DESCRIPTION</u>																						
0,1, and 2	These sections establish the default boot device, which is the drive type used to boot the operating system if you press the B key and the RETURN key at the hand prompt. The switch positions should be set to reflect the type of drive you want to use as the default boot device.																						
	<table border="1"> <thead> <tr> <th colspan="3"><u>Section</u></th> <th></th> </tr> <tr> <th><u>0</u></th> <th><u>1</u></th> <th><u>2</u></th> <th></th> </tr> </thead> <tbody> <tr> <td>OFF</td> <td>OFF</td> <td>OFF</td> <td>5.25-inch internal floppy disk drives.</td> </tr> <tr> <td>ON</td> <td>OFF</td> <td>OFF</td> <td>8-inch floppy disk drives.</td> </tr> <tr> <td>OFF</td> <td>ON</td> <td>OFF</td> <td>Winchester disk system.</td> </tr> </tbody> </table>			<u>Section</u>				<u>0</u>	<u>1</u>	<u>2</u>		OFF	OFF	OFF	5.25-inch internal floppy disk drives.	ON	OFF	OFF	8-inch floppy disk drives.	OFF	ON	OFF	Winchester disk system.
<u>Section</u>																							
<u>0</u>	<u>1</u>	<u>2</u>																					
OFF	OFF	OFF	5.25-inch internal floppy disk drives.																				
ON	OFF	OFF	8-inch floppy disk drives.																				
OFF	ON	OFF	Winchester disk system.																				
3	This section establishes whether autoboot is ON or OFF. Position the switch section to the ON position if you want to enable auto boot.																						
4	This position is not used.																						
5	This position is not used.																						
6	This position is not used.																						
7	This section selects the scan rate frequency. Position the switch section to ON for 50 Hz operation or OFF for 60 Hz operation.																						

Floppy Disk Controller

DS1 Switch Settings

Switch DS1 is located on the floppy disk card. To change any settings on the main switch you should remove the disk drive assembly. Once you have disassembled the computer to this point, refer to Figure G-22.

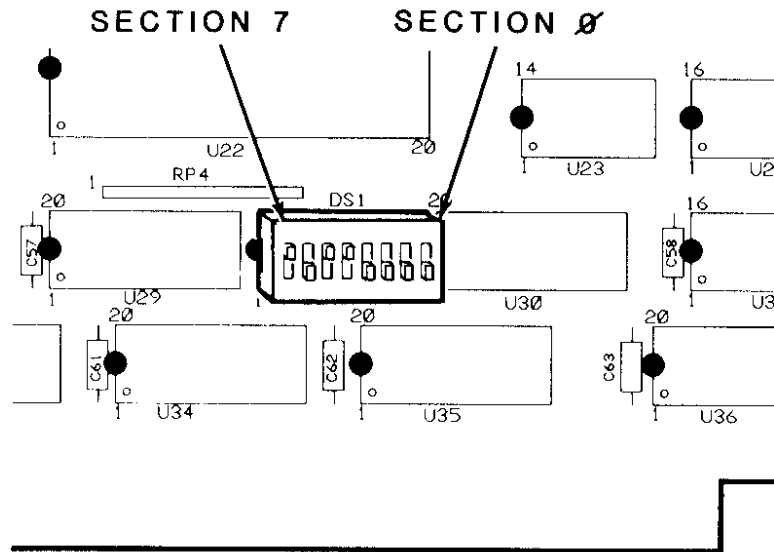

Figure G-22: Switch DS1 (Floppy Disk Card)

Although the sections of the switch are not marked on the card itself, the positions should be counted (numbered) from right to left as shown in the figure. The ON side of the switch may be installed toward the front or back of the computer. The ON side will always indicate the ON position of the switch. Move the switch sections to the ON or OFF position as needed to configure your system. The sections are described in Table G-2.

Table G-2: DS1 Floppy Disk Controller Switch Settings

SECTION DESCRIPTION

- | | |
|--------|---|
| 0 | This section selects the 5.25-inch disk drive type. Position the switch section to ON if you want to use 96 tpi disk drives or to OFF if you want to use 48 tpi disk drives. Your computer and software normally support 48 tpi, 5.25-inch disk drives. |
| 1 | This section selects precompensation for 5.25-inch disk drives. Position this section to ON if you want precompensation or to OFF if you do not want precompensation. |
| 2 | This section is not used. |
| 3 to 7 | These sections are used to establish the port base address of the floppy disk controller board. Normally the switches are:

(3) OFF,

(4) ON,

(5) ON,

(6) OFF, and

(7) ON. |

Video Board Jumpers

The jumpers on the video board determine the type of video RAM devices used in the computer, RGB or monochrome output, and the RGB video output synchronization signals. The pinouts of the RGB connector (J9) are described in Table G-3 and illustrated in Figure G-23. The jumpers are described in Table G-4 and their locations are shown in Figure G-24.

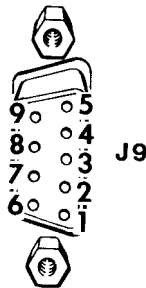

Figure G-23: RGB Connector (J9)

Table G-3: RGB Connector (J9) Pinouts

PIN	SIGNAL
1	Ground
2	Ground
3	Red
4	Green
5	Blue
6	Not connected
7	Not connected
8	Horizontal sync
9	Vertical or composite sync

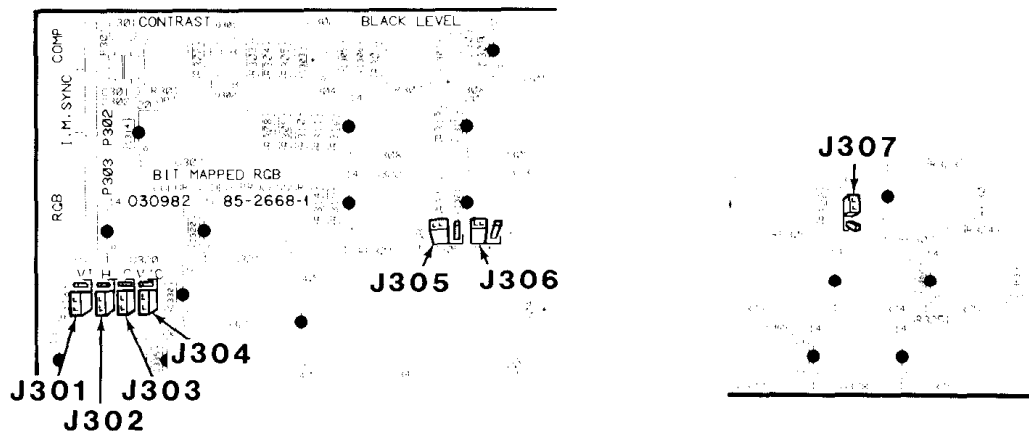

Figure G-24: Video Board Jumpers

Table G-4: Video Board Jumpers

<u>JUMPER</u>	<u>DESCRIPTION</u>
J301	This jumper selects the vertical synchronization polarity for use by the internal monitor of the All-in-One model. The "-" position will produce a negativegoing synchronization signal.
J302	This jumper selects the horizontal synchronization polarity at pin 8 of the RGB connector. The " " (unmarked) position will produce a negative-going synchronization signal at pin 8.
J303	This jumper selects the signal sent out of pin 9 of the RGB connector. If the jumper is in the "C" position, then pin 9 will have a composite synchronization (combined horizontal and vertical synchronization) signal. If the jumper is in the "V" position, pin 9 will carry the vertical synchronization signal.
J304	This jumper selects the polarity of either the composite or vertical synchronization signal on pin 9 of the RGB connector.

Table G-4 (continued): Video Board Jumpers

<u>JUMPER</u>	<u>DESCRIPTION</u>
J305	This jumper selects an RGB (the color option if all three banks of video RAM is filled) or a monochrome display output. Used in conjunction with J306. Place both jumpers in the "RGB" position to select the color option (all three banks of video RAM must be installed) or in the "G" position to select a monochrome output. Note that this selects the video capability of the system; you may use either type of the display (color or monochrome) with the computer.
J306	This jumper is used with J305 and selects an RGB or monochrome output. Set this jumper so that it is in the same position (RGB or G) as J305. See the description for J305.
J307	The position of this jumper indicates the video memory addressing option and type of video memory ICs used. No jumper indicates that the memory ICs will be 32-kilobit devices addressed to high memory (the upper 32 kilobytes of the possible 64 kilobytes in each bank). A jumper in the "32" position indicates that the ICs are 32-kilobit devices and addressed to low memory (the lower 32 kilobytes of 64 kilobytes in each bank). A jumper in the "64" position indicates that the ICs are 64-kilobit devices.

System Specifications

This appendix lists the specifications of the Z-1 00 Computer and its integral peripheral products.

CPU

8-bit processor 8085.

CLock

5 MHz.

Type

8-bit CPU.

Wait states

Memory, 1; input/output, 2.

16-bit processor

8088.

Clock

5 MHz or 8 MHz.

Type

16-bit CPU.

Wait states

Memory, 0; input/output, 2.

On-board memory

64K to 192K in 64K increments, 128K or 192K standard, parity checked; or 256K to 768K bytes in 256K increments, 256K standard, parity checked.

Memory space

1 megabyte.

Monitor program space

One 64K page (16K used).

Video RAM space

Three 64K pages - one 64K page for each color: red, green, blue.

User-memory space

3/4 megabyte (768K).

Interrupts

Controller

Dual 8259A integrated circuits.

System

15-level priority vector interrupt.

Video Display

CRT (All-in-One model)	12" diagonal, green nonglare screen.
Display format	25 rows of 80 characters.
Display size	6.5" high x 8.5" wide.
Character size	0.2" high x 0.1 "wide (approximately)
Character type	5 x 9 dot matrix.
Character set	Dynamically redefinable.
Dot resolution	640 dots horizontally x 225 dots vertically.
Colors (optional)	Eight: black, blue, cyan, green, magenta, red, white, and yellow. Gray scale Eight levels when you are using a monochrome display and the color option is installed in the computer.
Options	
Interlace mode	640 x 512 pixel resolution.
Pages	A second page of display.
Light pen	One-pixel resolution.
Outputs	Red, green, blue, composite monochrome video, composite sync, separated horizontal and vertical sync.

Bus Structure

Type	ANSI/IEEE Std 696-1983 (S-100).
Number of card slots	Five.
Data bus width	Eight bits.
Address bus width	24 bits.
input/output addressing	Eight bits.

Timer

Type Programmable.

Keyboard

Type 95 keys (61-key alphanumeric and 16-key function and control section (main keyboard), plus an 18-key numeric and control section (keypad).

Maximum key debounce 5 milliseconds.

Modes Two: ASCII and event driven.

Processor 8041 A universal peripheral interface.

Buffer FIFO (first-in, first-out) buffer (17 character).

Key click May be disabled.

Auto repeat 11 keys per second. May be disabled.

Fast repeat 28 keys per second.

Floppy Disk Controller

The floppy disk controller is located on an S-100 card and therefore, may be omitted from the computer system.

Type	Western Digital WD1 797.
Drives supported	Up to four of each type.
5.25-inch	Single- and double-sided, 48 or 96 tracks per inch, single- and double-density.
8-inch	Single- and double-sided, single- and double-density.
Data separator	Phase-locked loop.
Precompensation	Independently variable for both 5.25-inch and 8-inch disk drives.
Data transfer	Programmed using wait states.
Type	Interrupt or polling.
Internal disk drives	
Size	5.25-inch
Sides	One or two (software selectable)
Tracks per inch	48 or 96
Capacity (formatted)	160K, 180K, 320K, 360K, 640K, or 720K, depending upon the number of sides, tracks per inch, and operating system used.
Track format	8 or 9 sectors of 512 bytes each, dependent upon the operating system.
Stepping speed	6 milliseconds per track or faster.
External 8-inch disk drives	Optional.
Size	8-inch.
Sides	One or two (disk dependent).
Compatibility	Shugart.
Winchester disk drive	Optional.
Number	One or two, replacing one or both internal 5.25-inch floppy disk drives.
Capacity (formatted)	5, 10, or 20 megabytes.
Compatibility	Seagate.

Input/Output

Serial input/output	Dual RS-232 ports, one DTE and one DCE type.
Baud rate	110 to 38400 baud (software selectable).
Operation	Asynchronous RS-232 or synchronous.
Stop bits	One, one and one-half, or two bits.
Word length	Five, six, seven, or eight bits.
Parity	Odd, even, or no parity.
Break capability	Detection and generation.
Parallel output	
Compatibility	Centronics-type.

Power Supply

Input, volts	115 or 230 VAC.
Input, hertz	50 or 60 Hz.
Operating temperature	15.6 to 32.2 degrees Celsius (60 to 90 degrees Fahrenheit).
Operating humidity	8 to 80% noncondensing.

NOTE: Zenith Data Systems Corporation reserves the right to discontinue products and to change specifications at any time without incurring any obligation to incorporate new features in products previously sold.

CP/M-85 Disk Operating System

Several alternative operating systems are available for your computer. One of the systems is CP/M-85 from Digital Research, Inc. It is similar to MS-DOS, but has several important differences. The tables in this appendix highlight those differences.

NOTE: CP/M-86 is an optional operating system that is very similar to CP/M-85, but takes advantage of the faster 8088 16-bit processor in the Z-100.

The commands are listed in alphabetical order where possible, according to the commands in MS-DOS.

Table I-1: MS-DOS and CP/M-85 Control Functions

<u>KEY(S)</u> <u>PRESSED</u>	<u>MS-DOS</u>	<u>CP/M-85</u>	<u>DESCRIPTION</u>
BACK SPACE	x	x	Back space and delete character.
CTRL-C	x	x	Exit from the current function (CP/M: force a warm reboot of the operating system).
CTRL-E		x	Extend current logical line to next physical line.
CTRL-L		x	Substitute CR and LF.
CTRL-N	x		Disable the printer echo.
CTRL-P	x	x	Enable the printer echo (CP/M: toggle the printer echo on or off).
CTRL-R		x	Display the current command line.
CTRL-S	x	x	Suspend all operation. Press any key to continue.
CTRL-U		x	Delete the current command line.
CTRL-X	x	x	Cancel the current line.
CTRL-Z		x	End input from keyboard (PIP and ED).
LINE FEED	x	x	Extend current logical line to next physical line.
RETURN	x	x	Execute current command line.
TAB	x	x	Move cursor to next tab column.

CP/M-85 Disk Operating System

Table 1-2: MS-DOS and CP/M-85 Commands

MS-DOS	CP/M	DESCRIPTION
<filename>.BAT	SUBMIT filename.SUB XSUB	Execute a file with a .BAT extension as a batch processing file. CP/M uses a file with a SUB extension. XSUB is an extended batch processor and allows many of the same functions that are in the MS-DOS batch processor.
APPLY	—	Execute a given command multiple times, substituting a selected parameter.
—	ASM	Create object code files from assembly language code. Note that this is an 8-bit 8080 assembler which produces code recognized by the 8085 in the Z-100. An optional software package, <i>The Programmer's Utility Pack</i> contains an assembler for MS-DOS, MASM, which produces code for the 8088 processor in the Z-100.
ASSIGN	ASSIGN	Assign a logical drive name to a Winchester disk partition.
BACKUP	BACKUP	Create a single archive file from one or more active files.
BREAK	—	Turn on or off check for CTRL-C whenever system access is performed.
CD/CHDIR	USR	Change or display the current directory. USR changes the user number. The user feature of CP/M is similar to the subdirectories of MS-DOS except that CP/M does not have a hierarchal directory structure. Each user in CP/M is treated as if it were the only directory on the disk; the other directories are invisible to the current user.

CP/M-85 Disk Operating System

Table 1-2 (continued): MS-DOS and CP/M-85 Commands

MS-DOS	CP/M	DESCRIPTION
CHKDSK	STAT	Examine directory and file allocation table and report status. CP/M does not check for consistency, since the type of inconsistency checked by MS-DOS cannot occur in the CP/M system. CP/M does provide information on a by-file basis, if requested.
CIPHER	—	Encrypt or decrypt a file.
CLS	—	Clear the screen.
COMMAND	—	Execute the command processor.
CONFIGUR	CONFIGUR	Configure system input/output parameters. This utility is not considered part of either MS-DOS or CP/M, but is provided by Zenith Data Systems so that you can interface MS-DOS (or CP/M) with your computer.
COPY	PIP	Copy one or more files.
CREF	—	Build a cross reference file.
CTTY	—	Change command input/output device to AUX or CON.
DATE	—	Display and/or change current system date.
DEBUG	DDT	Activate the debugging utility.
DEL/ERASE	ERA	Delete (erase) one or more files. CP/M does not support multiple directories, but it does support multiple user directories.
DIR	DIR	Display all or selected entries of the current/specified directory.

CP/M-85 Disk Operating System

Table 1-2 (continued): MS-DOS and CP/M-85 Commands

MS-DOS	CP/M	DESCRIPTION
DISKCOMP	DUP	Compare two disks. CP/M uses a feature of DUP to accomplish the task.
DISKCOPY	DUP	Duplicate a disk.
ECHO	—	Control display during batch processing.
F.EDLIN	ED	Create and maintain ASCII text file.
EXE2BIN	LOAD	Convert EXE file to binary format (COM). LOAD, in CP/M, has the ability to convert a hexadecimal file into a .COM file.
EXIT	—	Exit the command processor to previous level.
FC	—	Compare two files.
FIND	—	Search for a string in one or more files.
FONT	—	Enable font editor or load alternate character set.
FOR...IN...DO...	—	Loop processing feature of batch processor.
FORMAT	FORMAT	Formats disk surface.
GOTO...	—	Unconditional branch feature of batch processor.
IF [NOT]	—	Conditional feature of batch processor.
LIB	—	The library manager.
LINK	PREL	Creates executable files from object code.

CP/M-85 Disk Operating System

Table 1-2 (continued): MS-DOS and CP/M-85 Commands

MS-DOS	CP/M	DESCRIPTION
—		LOAD Load a hexadecimal file from disk into memory. Convert a hexadecimal file into a .COM file. DEBUG, in MS-DOS, has the ability to load a hexadecimal file from disk into memory. EXE2BIN, in MS-DOS, has the ability to convert EXE files into .COM files.
MAP	STAT	Reassign logical drive names to different physical drive. STAT can also report the status of individual file names and disk space remaining. In the regard, it is much like the MS-DOS command, CHKDSK.
MD/MKDIR	USR	Create a directory. USR is used in a similar manner, except the directories are treated differently. See the comments under CD/CHDIR.
MORE	—	Send output a screen at a time.
—	MVCPM207/217	Prepare the operating system for transfer to another disk type (floppy disk to Winchester system or vice versa).
PATH	—	Specify directory or directories to be searched to execute external MS-DOS commands.
PAUSE	—	Suspend action of batch processor.
PRINT	—	Initiate background printing of file(s).
PROMPT	—	Change MS-DOS system prompt.
PSC	—	Load screen dump utility into memory.

CP/M-85 Disk Operating System

Table 1-2 (continued): MS-DOS and CP/M-85 Commands

MS-DOS	CP/M	DESCRIPTION
RDCPM	—	Read CP/M directories or copy CP/M files to MS-DOS . CP/M-85 has no equivalent utility. However, the Zenith Data Systems version of CP/M-86 has a utility that can read MS-DOS disks and copy files to the CP/M operating system disks.
RECOVER	—	Recover file(s) that have been erased or deleted from the disk.
REM	;	Display message during batch processing.
REN/RENAME	REN	Rename a file.
RESTORE	RESTORE	Restore archived files.
RD/RMDIR	—	Remove specified directory.
—	SAVE	Save a file (machine code) to disk. This feature is part of the MS-DOS utility, DEBUG.
SEARCH	—	Locate a file.
SET	—	Set one string equivalent to another.
SHIFT	—	Allow more than 10 parameters in batch processor.
SORT	—	Displays results in sorted order.
SYS	SYSGEN/BSYSGEN	Transfer operating system files from source drive disk to destination disk.
TIME	—	Display and/or change current system time.
TYPE	DUMP/LIST	Display contents of specified file.
VER	—	Display the version numbers of MSDOS.SYS and IO.SYS.

CP/M-85 Disk Operating System**Table 1-2 (continued): MS-DOS and CP/M-85 Commands**

MS-DOS	CP/M	DESCRIPTION
VERIFY	—	Display or change condition of verify function.
VOL	—	Display volume name of disk in default or specified drive.

Using Z-89 Software on the Z-100

Most Zenith Data Systems/Heath Z-89 software application packages that are distributed to run under CP/M versions 2.2.02, 2.2X03, 2.2.03, and 2.2.04 (referred to as CP/M-80 software) may be converted to run on the Z-100. A list of convertible software packages appears in Table J-1.

CP/M-80 software is widely used on computers that use the 8080 or Z80 microprocessors. The Zenith Data Systems Z-89 and Z-90 computers and the Heath H-88, H-89, and H-8 computers are represented by "Z-89" in this appendix.

The convertible CP/M-80 software is distributed on three different types of media: 5.25-inch hard-sectored disks, 5.25-inch soft-sectored disks, and 8-inch soft-sectored disks. The instructions contained in this appendix will allow you to transfer CP/M-80 software to disks that can be used by the Z-100 with CP/M-85. The step-by-step procedure and equipment you will need is outlined on the following pages.

Your computer is shipped with one or two 5.25-inch disk drives that work with soft-sectored disks containing data formatted on 48-tracks per inch, single- or double-density, single- or double-sided media. Because the computer cannot read data stored on disks in other formats, the files contained on most CP/M-80 disks must first be converted to a Z-100-compatible format.

As an alternative, a Z-89 with the appropriate controller and disk drive(s) and a Z-100 with two 5.25-inch disk drives and CPS (or other communications transfer software) for CP/M-80 on the Z-89 and CPS (or other communications transfer software) for CP/M-85 on the Z-100. You will also need an RS-232 cable to connect the two computers via their RS-232 ports. Then you may use the software on each computer and transfer your files directly from the Z-89 to the Z-100.

The way you convert from one format to another depends upon the format, type, and size of the disks that now hold your CP/M-80 software.

- If your files are stored on 5.25-inch, soft-sectored, 48 tracks per inch disks, or on 8-inch soft-sectored disks, then follow procedure one.
- If your files are stored on 5.25-inch, hard-sectored disks, then follow procedure two.

- If your files are stored on 5.25-inch, soft-sectored, 96 tracks per inch disks, then follow procedure three.

NOTE: The procedures describe the sequence of activities necessary to transfer software stored on any CP/M-80 disk to a disk for use with the Z-1 00. The application software instructions are contained in the documentation that accompanies that software.

Transfer Procedure One

If you have CP/M-80 software on 5.25-inch, soft-sectored, 48-tracks per inch disks, or on 8-inch soft-sectored disks, they may be used directly on the Z-100 without modification. However, the Z-100 cannot use the CP/M-80 operating system. Use the following procedure to convert the application software to CP/M-85 disks.

Equipment Needed

To convert 5.25-inch CP/M-80 software to 5.25-inch CP/M-85 disks, you will need a Z-100 with two 5.25-inch disk drives; CP/M-85 configured as a working disk that contains FORMAT.COM, BSYSGEN.COM, and PIP.COM; and a sufficient quantity of 5.25-inch soft-sectored blank disks to accommodate the number of files you wish to transfer.

To convert 8-inch CP/M-80 software to 5.25-inch CP/M-85 disks, you will need a Z-100 with one 5.25-inch disk drive and one 8-inch disk drive; CP/M-85 configured as a working disk that contains FORMAT.COM, BSYSGEN.COM, and PIP.COM; and a sufficient quantity of 5.25-inch soft-sectored blank disks to accommodate the number of files you wish to transfer.

To convert 8-inch CP/M-80 software to 8-inch CP/M-85 disks, you will need a Z-1 00 with two 8-inch disk drives; CP/M-85 configured as a working disk that contains FORMAT.COM, BSYSGEN.COM, and PIP.COM; and a sufficient quantity of 8-inch soft-sectored blank disks to accommodate the number of files you wish to transfer.

Transfer Procedure

If you are using 8-inch disks for both CP/M-80 and CP/M-85 files, the procedure will be the same you would use for 5.25-inch disks except that you will be using 8-inch disks in 8-inch disk drives instead of 5.25-inch disks in 5.25-inch disk drives.

- Prepare a label for each blank disk, using the names of the files you wish to transfer to it and the name, "Transfer Disk."
- Turn on your computer and boot the CP/M-85 operation system. When it is loaded, the display will show the following default drive prompt.

A>

- Insert your CP/M-85 working disk into drive A.
- Format each of your transfer disks in drive B by inserting the disk into drive B. Then enter the following command line.

FORMAT B: [N]

- Press the **RETURN** key. If you are using 5.25-inch disks, your computer will format the disk for double-sided, double-density use. If you wish to use another format, you will have to answer to prompts for the number of sides and density. Format all your blank disks now.
- Prepare each of your transfer disks with SYSGEN. Insert the blank, formatted disk in drive B and enter the following command line.

BSYSGEN B: =A: [B,N]

- Press the **RETURN** key. BSYSGEN will copy the CP/M-85 operating system to the disk. Do this with all your transfer disks now.
- Now copy the Peripheral Interchange Program (PIP.COM) to each transfer disk. Insert the transfer disk in drive B and enter the following command line.

PIP B: =A: PIP. COM [V]

- ❑ Press the **RETURN** key. PIP will copy the program (itself) to the transfer disk. (if you wish to copy additional CP/M programs (files) to the transfer disk, do so now by using PIP, specifying the appropriate file names. You will find instructions in the CP/M-85 documentation.) Copy PIP.COM (along with any other CP/M-85 programs) to all your transfer disks now.
- ❑ Remove your CP/M-85 working disk from drive A.
- ❑ Insert one of the prepared transfer disks into drive A.

If you are transferring either 5.25-inch CP/M-80 files to 5.25-inch CP/M-85 disks or 8-inch CP/M-80 files to 8-inch CP/M-85 disks, continue with the following. Otherwise, if you are transferring 8-inch CP/M-80 files to 5.25inch disks, proceed to "8-inch Source Disks."

5.25-inch Source Disks

- ❑ Transfer the CP/M-80 software to the prepared transfer disks. Insert one of the CP/M-80 disks into drive B and enter the following command line.

```
PIP A: =B: *. * [V]
```

- ❑ Press the **RETURN** key. The computer will load the PIP program into memory and transfer the files from the disk in drive B to the CP/M-85 disk in drive A.

CP/M-85 uses the wild card * . * to transfer all the files from the CP/M-80 disk to the CP/M-85 transfer disk. After all the files have been transferred, your computer will once again display the CP/M-85 prompt.

- ❑ At this point, remove both disks. If you have more files to transfer to the CP/M-85 system, insert the appropriate CP/M-80 disk into drive B and a new CP/M-85 transfer disk in drive A and repeat the process.

8-inch Source Disks

- Transfer the CP/M-80 software to the prepared transfer disks. Insert one of the CP/M-80 disks into your 8-inch disk drive (referred to as drive C) and enter the following command line.

```
PIP A: =C: *. * [V]
```

- Press the **RETURN** key. The computer will load the PIP program into memory and transfer the files from the 8-inch disk in drive C to the 5.25-inch CP/M-85 disk in drive A.

CP/M-85 uses the wild card *. * to transfer all the files from the CP/M-80 disk to the CP/M-85 transfer disk. After all the files have been transferred, your computer will once again display the CP/M-85 prompt.

NOTE: There is a possibility that your 8-inch disk may hold more files than the 5.25-inch CP/M-85 disk can accommodate. If this is the case, an error message will be generated and you will have to split the files from your 8-inch disk between two or more 5.25-inch transfer disks.

- At this point, remove both disks. If you have more files to transfer to the CP/M-85 system, insert the appropriate CP/M-80 disk into drive B and a new CP/M-85 transfer disk in drive A and repeat the process.

Transfer Procedure Two

To transfer CP/M-80 software on 5.25-inch hard-sectored disks, you will first have to transfer it to 5.25-inch, 48-tracks per inch, soft-sectored disks and then to Z-100 disks (if you wish to boot from them).

Equipment Needed

You will need a Z-89 computer with a soft-sectored controller (Z-89-37) and at least one 5.25-inch, 48-tracks per inch disk drive; one hard-sectored disk controller and at least one 5.25-inch, 48-tracks per inch disk drive; CP/M-80 properly configured for the hard/soft-sectored system containing FORMAT.COM and PIP.COM; A Z-100 computer with two 5.25-inch disk drives; CP/M-85 configured as a working disk with FORMAT.COM, BSYSGEN.COM, and PIP.COM; and a sufficient quantity of blank 5.25-inch disks to accommodate at least twice the number of files you wish to transfer.

NOTE: As you can see, a considerable amount of equipment is required. If you do not have all the necessary equipment, you may wish to contact your Zenith Data Systems full-line dealer regarding the use of his demonstration equipment to make the transfer of this software.

Transfer Procedure

- Prepare labels for about half of the 5.25-inch disks, using the names of the files that you will transfer to them and the words "Conversion Disk."
- Boot the Z-89 system using CP/M-80.
- Format each of the soft-sectored conversion disks by inserting them, one at a time, into the 5.25-inch, 48-tracks per inch disk drive and entering the following command line.

FORMAT

- Press the **RETURN** key and answer the prompts. If you plan to use the 5.25-inch disks directly on your Z-100, enter 2 for the number of sides and D for density. Refer to your CP/M-80 documentation for instructions to use the **FORMAT** command of CP/M-80. Use the same procedure to format all the conversion disks now.

- Place the operation system on each of the conversion disks. Insert each disk into the soft-sectored drive (the same drive you used to format the disks) and enter the following command line.

SYSGEN

- Press the **RETURN** key. When the following line is displayed, enter the name of the drive that contains your source disk (this is the disk from which you booted the Z-89).

SOURCE DRIVE NAME (OR RETURN TO SKIP):

- When the following line is displayed, press the Y key.

COPY BIOS.SYS (Y/N):

- When the following line is displayed, press the key that corresponds to the name for that drive. This will be the same drive name you used to format the conversion disks.

DESTINATION DRIVE NAME (OR RETURN TO REBOOT):

- Use this same procedure and put the system on the remainder of the conversion disks now.

- Place the Peripheral Interchange Program (PIP.COM) on each of the conversion disk with PIP. Use the proper drive names for the source and destination disk drive. (They will be the same as you used in the previous procedure.) Do this for each of the conversion disks now.

- Copy your CP/M-80 software to the conversion disks. Run the Peripheral Interchange Program (PIP) as instructed in the CP/M documentation. Be sure you know which files you are transferring to your conversion disks. Do this for all the CP/M-80 software now.

You have completed your work with the Z-89 computer. Follow transfer procedure one to complete the transfer process (if you want to make Z-1 00-bootable disks) of your CP/M-80 files. Whenever transfer procedure one calls for a CP/M-80 disk, use the conversion disk instead.

Transfer Procedure Three

CP/M-80 software supplied on 5.25-inch, soft-sectored, 96-tracks per inch disks must be transferred to 48-tracks per inch disks to use on the Z-1 00.

Equipment Needed

You will need a Z-89 computer with a soft-sectored controller (Z-89-37) and one 5.25-inch, 48-tracks per inch disk drive connected to one disk output port and one 5.25-inch, 96-tracks per inch disk drive connected to the other disk output port; CP/M-80 with PIP.COM and STAT.COM, configured for the two different types of disk drives; a Z-100 computer with two 5.25-inch disk drives; a CP/M-85 working disk (bootable) that contains FORMAT.COM, BSYSGEN.COM, and PIP.COM; and sufficient 5.25-inch soft-sectored disks to accommodate at least twice the number of files you wish to transfer.

Even though Zenith Data Systems does not support the mixed-drive density required on the Z-89 in this procedure, you can transfer files from 96-tpi disks to 48-tpi disks with little or no difficulty once CP/M-80 is properly configured.

Transfer Procedure

- Prepare labels for about half of the 5.25-inch disks, using the names of the files that you will transfer to them and the words "Conversion Disk."
- Boot the Z-89 system from the 5.25-inch, 96-tpi disk drive, with CP/M80.
- Format each of the conversion disks by inserting them, one at a time, into the 5.25-inch, 48-tracks per inch disk drive and entering the following command line.

FORMAT

- Press the **RETURN** key and answer the prompts. If you plan to use the 5.25-inch disks directly on your Z-100, enter 2 for the number of sides and D for density. Refer to your CP/M-80 documentation for instructions to use the FORMAT command of CP/M-80. Use the same procedure to format all the conversion disks now.
- Place the operation system on each of the conversion disks. Insert each disk into the soft-sectored drive (the same drive you used to format the disks) and enter the following command line.

SYSGEN

- Press the **RETURN** key. When the following line is displayed, enter the name of the drive that contains your source disk (this is the disk from which you booted the Z-89).

SOURCE DRIVE NAME (OR RETURN TO SKIP):

- When the following line is displayed, press the Y key.

COPY BIOS.SYS (Y/N):

- When the following line is displayed, press the key that corresponds to the name for that drive. This will be the same drive name you used to format the conversion disks.

DESTINATION DRIVE NAME (OR RETURN TO REBOOT):

- Use this same procedure and put the system on the remainder of the conversion disks now.
- Place the Peripheral Interchange Program (PIP.COM) and STAT.COM on each of the conversion disks with PIP. Use the proper drive names for the source and destination disk drive. (They will be the same as you used in the previous procedure.) Do this for each of the conversion disks now.
- Copy your CP/M-80 software to the conversion disks. You may need more than one conversion disk per CP/M-80 distribution disk. To copy the software, run the Peripheral Interchange Program (PIP) as instructed in the CP/M documentation. Be sure you know which files you are transferring to your conversion disks. Do this for all the CP/M80 software now.

You have completed your work with the Z-89 computer. Follow transfer procedure one to complete the transfer process (if you want to make Z-1 00 bootable disks) of your CP/M-80 files. Whenever transfer procedure one calls for a CP/M-80 disk, use the conversion disk instead.

Convertible Software

The list of CP/M-80 software products in Table J-1 may be converted and/or run on the Z-100 while you are using CP/M-85. In the Disk Format column of the table, "hard" refers to the hard-sectored disk format and "soft" refers to the soft-sectored disk format.

NOTE: The list in the table is a list of convertible software that may or may not still be available from your Zenith Data Systems dealer or Heath Company.

Table J-1: Convertible CP/M-80 Software

PROGRAM NAME	MODEL	DISK FORMAT	DESCRIPTION
SuperCalc™*	HSC-817-1	5.25-inch hard	SuperCalc is a worksheet program that is used for viewing and calculating business data. It performs math operations on all relevant statistics throughout the 63column, 254-row range of the worksheet. It also provides screen-displayed help messages.
	HSC-837-1	5.25-inch soft	
	HSC-847-1	8-inch soft	
General Ledger II	SF-9104	5.25-inch hard	General Ledger II is a low-cost accounting program for small business bookkeeping. It enables you to enter a custom chart of accounts, verifies equality of all double-entered debits and credits and displays balance statements. General Ledger II requires BASIC-80 to run.
	SFS-9104	5.25-inch soft	
Small Business Inventory	SFS-9105	5.25-inch soft	Small Business Inventory is an inventory program that displays and prints twelve statistics describing up to 1,000 parts that you stock.

Table J-1 (continued): Convertible CP/M-80 Software

PROGRAM NAME	MODEL	DISK FORMAT DESCRIPTION	
Microstat	HES-817-1 HES-837-1 HES-847-1	5.25-inch hard 5.25-inch soft 8-inch soft	Microstat is a flexible, menu-driven program for statistical analysis and data manipulation. It performs math operations, time series analysis, and several other functions.
WordStar™	HMP-817-2 HMP-837-2 HMP-847-2	5.25-inch hard 5.25-inch soft 8-inch soft	WordStar is a word processing program with advanced text editing/printing capabilities and screen-displayed help messages.
MailMergen™	HMP-817-3 HMP-837-3 HMP-847-3	5.25-inch hard 5.25-inch soft 8-inch soft	MailMerge is a WordStar supplement that enhances WordStar's printing capabilities by enabling you to print form letters, merging variable text, and to automatically print a number of files in succession. This program requires WordStar to operate.
Magic Wand	HRS-817-9 HRS-837-9 HRS-837-9	5.25-inch hard 5.25-inch soft 8-inch soft	Magic Wand is a word processing program with video screen text editing and form letter printing capabilities.
SuperSort™	HMP-817-1 HMP-837-1 HMP-837-1	5.25-inch hard 5.25-inch soft 8-inch soft	SuperSort is a data organization program that quickly sorts and combines data from several different files. It accepts data from many different record formats and provides screen-displayed help messages.
DataStar™	HMP-817-4 HMP-837-4 HMP-837-4	5.25-inch hard 5.25-inch soft 8-inch soft	DataStar is a data organization program that enables you to generate forms for entering data, to store the data in files, and to retrieve the data quickly. It can perform math operations on the data and provides screen-displayed help messages.

Table J-1 (continued): Convertible CP/M-80 Software

PROGRAM NAME	MODEL	DISK FORMAT	DESCRIPTION
WordMaster™	HMP-817-1	5.25-inch hard	WordMaster is an economical text editing utility program that enables you to compose text files and store them on disk for program development and/or correspondence.
	HMP-837-1	5.25-inch soft	
	HMP-847-1	8-inch soft	
Despool	HDR-817-3	5.25-inch hard	Despool is a time-saving utility that coordinates printing operations.
	HDR-837-3	5.25-inch soft	
SID/ZSID	HDR-817-2	5.25-inch hard	SID/ZSID is a debugging utility that enables you to display and change portions of an assembly 8-inch soft language program by accessing assembly mnemonics in source files or hexadecimal code in object files.
	HDR-837-2	5.25-inch soft	
	HDR-847-2		
Macro Assembler	HDR-817-1	5.25-inch hard	A Macro Assembler is an advanced assembler utility that makes program development and assembly easier. It uses the assembly language designed for the ASM utility and includes many useful macro utilities.
	HDR-837-1	5.25-inch soft	
	HDR-847-1	8-inch soft	
MACRO-80	HMS-817-52	5.25-inch hard	MACRO-80 is a fast and versatile utility for assembling 8080 or Z80 building libraries of source code, relocatable modules, linking modules from several languages into executable object code, and cross referencing variable names and line numbers.
	HMS-837-52	5.25-inch soft	
	HMS-847-52	8-inch soft	
CBASIC®	HCM-817-1	5.25-inch hard	CBASIC is a noninteractive BASIC programming tool that includes a pseudo-code compiler and a run-time interpreter. It includes programs to convert source files into executable object files and a program to list all variables used in a source file.
	HCM-837-1	5.25-inch soft	
	HCM-847-1	8-inch soft	

Table J-1 (continued): Convertible CP/M-80 Software

PROGRAM NAME	MODEL	DISK FORMAT	DESCRIPTION
Pearl III	HCP-837-1 HCP-849-1	5.25-inch soft 8-inch soft	Pearl III is a menu-driven program generator that enables users without programming experience to design and produce custom application programs that can manipulate up to three files at one time. Prompts the user to specify what the program should do, and converts these specifications into a CBASIC source file.

Magic Wand Function Key Guide

Some of the features of the Magic Wand word processor are performed on the Z-89 by pressing keys that do not exist in the same form on the Z-100 keyboard. This guide will help you to determine which keys are available for these functions on the Z-100.

Table J-2 shows the Z-100 keys you can press to duplicate the Magic Wand functions you performed on the Z-89 computer.

Table J-2: Magic Wand Z-89 to Z-100 Function Key Guide

Z-89 KEY	Z-100 KEY	FUNCTION
f1	F1	Backward line scroll.
f2	F2	Forward line scroll.
f3	F3	Backward page scroll.
f4	F4	Forward page scroll.
f5	F5	Page feed.
blue	F6	Search and replace.
red	F7	Repeat search.
white	F8	Set block marker.
IC/7	I CHR	Toggle the character insertion on or off.
DC/9	D CHR	Delete the current word.
IL/1	INS LINE	Toggle the full insert on or off.
DL/3	DEL LINE	Delete the current line.
↑	↑	Move the cursor up one line.
↓	↓	Move the cursor down one line.
→	→	Move the cursor one character to the left.
←	←	Move the cursor one character to the right.
HOME	HOME	Move the cursor to the home position.

Interactive Business Graphics

Introduction

This appendix contains the additional instructions for using your demonstration disk programs. In particular, these instructions deal with the Interactive Business Graphics programs (selection F2).

After you are familiar with BASIC, you are invited to "take the programs apart" and examine the various routines contained in them. If you have purchased GW-BASIC, instead of Z-BASIC, you will need to convert the programs, using the TOKEN program that is distributed with GW-BASIC. Refer to the GW-BASIC documentation for instructions.

The Interactive Business Graphics Program

The business graphics charts are produced in a three-step process: first, create and/or modify data file(s); second, create a graphic design; and third, draw the display. The data may be kept (stored on disk) for as long as you need it. A data file that is used with one type of chart may be used with any of the other six types of charts.

NOTE: Do not use a write-protected disk.

To use the program, proceed with the following.

At the master menu, press the **F2** key. After a few moments, the screen will clear and display four options and three "windows."

The left window shows you typical data information. This represents option 1, the data management routines. The routines allow you to create, change, or print out a data file that you may later use to create one or more business graphs. Press the **F1** key to proceed to the data management routines.

Interactive Business Graphics

- The right window tells you what kind of display is being used in the center window. This represents option 2, the graphic design section. It allows you to specify the format of the display. In addition, you will specify the title, data labels, and the data file(s) that are to be used. Press the F2 key to proceed to the graphic design routines.
- The center window shows a miniature version of a display created from the information that you see in the left and right windows. This represents option 3, the graphic display. It creates the display that you have specified. Press the F3 key to display the graph you have selected.
- The continuous demonstration will display a series of charts that have been created using the same three steps that you can use to create your own charts. Each of the seven types of charts is shown during this demonstration.

NOTE: If your computer does not have the color video option, you will only see five of the charts; the program detects the presence or absence of the color option and displays a message in place of the graph.

To design your own chart, proceed with the following steps and enter the data as instructed. Later, after you get a feel for this program, you will be able to proceed without specific instructions. The program has been designed with prompts to lead you through the process. After this first session, you will be able to use your own data.

Interactive Business Graphics

The Data Management Routines

- From the demonstration disk's main menu, press the F2 key to proceed to the interactive business graphics menu.
- To set up, modify, or print a data file, press the F1 key. The screen will clear and display the following menu.

```
Data Management Routines
Enter Your Choice:
<F1> Create a New Data File
<F2> Modify existing Data File
<F3> Print a Data File
<HOME> EXIT
Press Function key indicating your choice >
```

This menu gives you several options. When you press the F1 key, you will be able to create a new data file and enter data into it. If you have an existing file on the disk, you can modify or change the data in it by selecting the F2 option. To print the information stored in a data file, you would press the F3 key. If you want to return to the interactive business graphics menu, press the HOME key.

Create New Data File

- Press the **F1** key. The screen will clear and display the following.

```
Create New Data File
Enter name for new file or EXIT >*****
```

Interactive Business Graphics

To return to the main menu enter the word "exit" in either all uppercase letters or all lowercase letters and press the **RETURN** key. If you use a combination of upper- and lowercase letters, the program will not recognize the word and will treat it as the name of a data file. Do not use a combination of capital and lowercase letters.

Data file names follow a set of rules. More detail is provided in the "Disk Operating System" chapter of this manual. For now, remember that you may use only eight characters. The first character must always be a letter. Do not use punctuation (even though some are allowed, there aren't many, so for now, do not use any).

The file name is controlled by the program (it will not allow you to enter more than eight characters); therefore, do not attempt to enter an extension. The interactive business graphics programs assign specific extensions to your files.

- Enter a name for your file. For the first time through these instructions, enter the following name.

TEST

- Press the **RETURN** key.

If you use a name that has previously been assigned to a file, the program will display a message which will inform you that recreating the file will erase the old data. The program will then ask you if this is what you want to do. If you press the Y key in response to this prompt, then the program will continue. Otherwise, the program will prompt you to enter a new file name.

The computer will now display the following.

Number of data items (maximum=20)

>**

Before you enter the actual data into a file, you must tell the program how many items you are about to enter. The data files for this program are limited to twenty items. Your own programs may use more, but only if the program and graphic displays are adjusted for the larger number of items. The lower limit is set to two items, since this is the minimum necessary to create a meaningful chart.

Interactive Business Graphics

If you enter a number less than 2 or greater than 20, a message will be displayed that tells you that your number is out of range and that you must enter a valid number.

- Enter any number between 2 and 20, depending upon the number of items you have. For the first time through the program, enter 2 and press the **RETURN** key. The screen will clear and the following will be displayed.

Data Descriptions and values will now be entered.

Press **RETURN** after each line to continue with the next item.

Errors can be corrected after all items have been entered.

Enter Description for item #1 >***

- For the first time through the program, enter the following description.

January

- Press the **RETURN** key. The display will now show:

Enter value for January >*****

- For this prompt, enter 3 and press the **RETURN** key. The display will show:

Enter Description for item #2 >*****

- Enter February and press the **RETURN** key. The display will show:

Enter value for February >*****

- Enter 2 and press the **RETURN** key. This completes the second entry. Since you told the program you had only two items, you are now done with this section. You will now be automatically transferred to the second of the data management routines, the modify existing data file routine.

Interactive Business Graphics

Modify Existing Data File

- Press the **F2** key from the data management routines menu to start this part of the routines. Note that if you just created a new data file with the F1 key from the data management routines menu, you will automatically be sent to this routine after you enter your last data item.
- If you are entering this routine from the menu and not the create new data file routine, you will be asked for the data file to be modified. If the file cannot be found, a message will be displayed which tells you that the data file was not found. You may then enter the correct data file name or the word EXIT in all uppercase or all lowercase letters to get back to the menu.

After the data has been read from disk (if needed), the screen will clear and the data will be displayed in a manner similar to the following.

Modify Data

1) Description > January	Value> 3 (60.0%)
2) Description > February	Value> 2 (40.0%)

Enter item number to change (99) if done) >**

The data shown in this example was entered by following the steps in creating a new data file. Here, each item is identified by a number (1, 2 and etc.). To modify any particular line, enter the line number that identifies that line.

- To change the data displayed in line two, enter the number 2 and press the **RETURN** key. The screen will display the following.

Description (Default =February)	>*****
---------------------------------	--------

Interactive Business Graphics

- Since you don't want to change the description, press the **RETURN** key. Otherwise, you may modify the description by entering the correct information. The screen will flash the default and display the following line.

```
Enter new value or <RETURN> (Default=2)                >*****
```

- To change this value, enter a new number (enter 3) and press the **RETURN** key. After correct a line, the new values will be displayed and the percentages recomputed. You may correct another line using the same procedure, or you may exit this routine. To exit the routine, enter 99 and press the **RETURN** key. The screen will now display the following line.

```
Shall I save changes (Y/N)?
```

- Press the Y key. The screen will display the following.

```
** Saving file>    TEST.DAT**  
                2  
Data Output Completed.
```

The file is stored on the disk. The program will then return to the data management routines menu.

If you press the N key instead of the Y key, the screen would display the following line.

```
File not saved. Returning to menu...
```

The program will return to the data management routines menu.

Interactive Business Graphics

Print Existing Data File

- ❑ To print the contents of a data file on a printer, press the F3 key at the data management routines menu.
- ❑ When you are prompted to enter the name of a data file, enter the name of the file you want printed. Do not enter any file extension name. Press the **RETURN** key. If you do not want to print a file, enter either EXIT or exit and press the **RETURN** key. (The program will return to the data management routines menu.)
- ❑ If you entered the wrong name for a file, you will see an error message and then you will be given the opportunity to enter the correct name or return to the data management routines menu.
- ❑ You will be asked to press the RETURN key if your printer is ready. Before you do, check to make sure the printer is on and set up properly. Then press the **RETURN** key.
- ❑ After your file has been printed, you will be asked to enter the name of another file. This gives you the opportunity to print the data in another file or return to the data management routines menu. To exit this routine, enter either EXIT or exit and press the **RETURN** key.

Graphic Design Routine

The graphic design option of this demonstration is the second step you use to create a business graph. The first step was the entry of data into a file, which was stored for use in producing one or more graphs. Your next step is to provide the "visual" information needed to produce the graph. This information includes the following.

- The type of graph.
- The data file or files to be used to create the graph.
- The title of the graph.
- The X-axis label when needed.
- The Y-axis label when needed.

Interactive Business Graphics

- The X-axis descriptions or pie chart labels.
- The Y-axis minimum, maximum and increment values.
- The legends.
- The bar types.
- The pie pieces to be offset from the chart.

- ☐ To enter the specifications for the graph, press the F2 function key from the interactive business graphics menu. The screen will clear and a sample of each of the seven types of displays will be shown on the screen. Above each sample will be the name of the display and the respective function key. Table K-1 is a complete list of the function key and corresponding chart.

Table K-1: Graph Display Types

FUNCTION KEY	TYPE OF GRAPH
F1	Vertical bar chart.
F2	Single pie chart.
F3	Horizontal bar chart.
F4	Point-to-point line chart.
F5	Multiple pie chart.
F6	Trend-line analysis chart.
F7	Three-dimensional bar chart.

- ☐ Press the function key that corresponds to the chart you want to display. If you wish to return to the interactive business graphics menu, press the **HOME** key.
- ☐ Enter the specification requested for the type of chart you have selected. Table K-2 contains the information requested for each type of chart. The heading across the top of the chart contains the function key number that corresponds to the charts as described in Table K-1.

Interactive Business Graphics

Table K-2: Chart Specifications

	F1	F2	F3	F4	F5	F6	F7	NOTES
Number of files	1-4	1	1-4	1-4	2-8	1	1-2	1
File names	1-4	1	1-4	1-4	2-8	1	1-2	2
Chart title	x	x	x	x	x	x	x	3
X-axis label	x	n/a	x	x	n/a	x	x	4
Y-axis label	x	n/a	x	x	n/a	x	x	5
X-axis descriptions	x	n/a	x	x	n/a	x	x	6
Y-axis values	x	n/a	x	x	n/a	x	x	7
Legends	x	n/a	x	x	x	n/a	x	8
Bar layout	x	n/a	n/a	n/a	n/a	n/a	n/a	9
Bar spacing	x	n/a	n/a	n/a	n/a	n/a	n/a	10
Piece description	n/a	x	n/a	n/a	x	n/a	n/a	11
Piece offset	n/a	x	n/a	n/a	n/a	n/a	n/a	12

Notes:

1. The number of files that can be used for any chart can range from 1 to 8, depending upon the chart. The range is provided.
2. The file name is that of the data file. The number of names requested will depend upon the number of files you specified for the first question (unless the chart type only requires one file). Please note that if multiple files are specified, they all must have the same number of data items. Also note that pie charts and the three-dimensional bar chart do not allow for negative values within the data file.
3. The chart title is limited to 70 alphanumeric characters, including spaces.
4. The X-axis label is limited to 15 alphanumeric characters, including spaces.
5. The Y-axis label is also limited to 15 characters.
6. The default x-axis descriptions will be those you entered when you set up the data files.
7. The Y-axis values are the minimum and maximum values that have been calculated (along with the increment value) from your data file or files. If you override these defaults with new values, the relationship between these values is calculated according to the following formula.

$$\text{Increment} = \frac{\text{maximum} - \text{minimum}}{16}$$

8. The default legends will be the names of the data file or files.

Interactive Business Graphics

Table K-2 (continued): Chart Specifications

9. The bar layout may be specified as either normal (no overlap) or overlapping.
 10. The bar spacing may be specified as either stepped or spaced with gaps.
 11. The default piece descriptions are the data descriptions you entered when you set up the data files.
 12. The piece offset gives you the choice of several options including which piece to offset.
 13. If a data file is altered so that the data no longer fits within the minimum/maximum values specified during this procedure, then all designs that use the modified file must be respecified. Otherwise, an error may occur when the display is placed on the screen.
 14. If a data file that is used in a chart is not on the disk when that chart is displayed, an error will occur. The missing data file should be supplied by either copying it from another disk or entering the data with the Create Data File routine.
 15. Multiple pie displays are limited to a maximum of eight pies (files) of no more than eight data items per file (slices per pie).
 16. Bar and line charts are limited to fur files of twenty data items per file.
- Once you have finished specifying the design, you will be asked if you want to save the design. If you have made errors or have decided not to use the design, press the N key. The specifications will be ignored (not stored) and the program will return to the interactive business graphics menu.
- If you are satisfied with your specifications, press the Y key. The program will then prompt you for a file name under which the information will be stored. Enter a name without an extension and press the **RETURN** key. The program will store the data under the file name you entered and by the type of chart you specified. The program will return to the interactive business graphics menu.

Interactive Business Graphics

Displaying the Graph

When you have created the data file or files and specified the graph, you are ready to display the results.

- To display a design, press the F3 key from the interactive business graphics menu. The screen will clear and you will see the seven type of designs that can be created by this program.
- Press the function key that corresponds to the design you wish to display. The names of the design files that are stored on the disk will be displayed.
- Enter the name of the display that you wish to see. Do not enter the extension.
- Press the **RETURN** key. The screen will clear and the chart will be created from the specifications you provided earlier. To return to the interactive business graphics menu, press the **HOME** key.

This completes the instructions for using the demonstration disk that is included with your system. While these instructions have been brief, we hope you will have gained some insight into the power and strength of the Z-100 Series Computers from Zenith Data Systems Corporation.

Backups

This appendix will show you how to make backups of your important disks using two different methods. You will also be shown a way to make a suggested copy of MS-DOS to use as a basis for all your bootable software that use this operating system.

Using the DISKCOPY Utility to Make Backups

The DISKCOPY utility of MS-DOS can be used to duplicate or make backups of identical disks. If you wish to backup a disk to a different format (for instance, from 5.25-inch disks to 8-inch disks or from a Winchester partition to 5.25-inch disks or 8-inch disks) you must use the FORMAT and COPY procedure that is explained later in this appendix.

Likewise, if you want to backup only certain files, you would use the COPY command, formatting new disks as needed.

When you use the DISKCOPY utility, it does not have to be on the source disk. In the following example, you will use DISKCOPY to duplicate the second MS-DOS working disk. You will need a blank disk and the MS-DOS disk #1 working disk.

- Boot your computer from the MS-DOS disk #1 working disk.
- Enter the following command line.

```
DISKCOPY/V
```

- Press the **RETURN** key. The computer will locate the DISKCOPY file, load it and display a message similar to the following.

```
DISKCOPY version 2. 20  
Copyright(C) 1984 Zenith Data Systems Corporation
```

```
Source drive name? (A-H) _:
```

Backups

- Remove the disk in drive A and place the MS-DOS disk #2 working disk in drive A and close the door or latch.

- You will notice that the cursor is to the left of the colon. It is prompting you to enter the name of the disk drive in which the source disk is located. Press the A key. The computer will now show:

Destination drive name (A-H) _:

NOTE: This backup procedure does not check to see if your destination disk has data on it. Any information previously recorded on the disk will be erased and blank (empty) tracks will be placed on the disk, making it ready to receive new data. Be sure you are using a blank disk (or one that you wish to erase).

Insert a blank disk in drive B and close the door or latch. Press the B key. The computer will display:

Place the source disk in A and the destination disk in B.
Press RETURN when ready.

You have a chance to check that you have the correct disks in the proper drives. The source disk, MS-DOS disk #2 working copy, should be in drive A. The destination disk, a blank disk, should be in drive B. If you are not sure that they are correct, check them now.

You also may stop the duplication process now if you wish. To stop (or abort) the backup procedure, you would press *both* the **CTRL** and **C** keys at the same time. The computer would end the program and display ↑C on the screen, followed by the MS-DOS prompt. However, you *need* to make working copies of your distribution disks, so continue with the following procedure.

- With MS-DOS disk #2 working copy in drive A and a blank disk in drive B, press the **RETURN** key. The light in drive A will come on momentarily and then the light in drive B will come on. You will see the following on the screen.

Formatting destination...

Backups

When the light came on for drive A, the computer was checking the type of disk in drive A and the way the tracks were organized on the source disk. Next, it checked the type of disk in drive B. When it was satisfied that the disks were of an identical type (both soft-sectored, in this case), it displayed the message and began formatting, or organizing, the tracks and sectors so they matched those of the disk in drive A. After the destination has been formatted, the display will show:

Copying...

Now you will see the disk access indicators in drive A and drive B alternately come on. While the indicator in drive A is on, the computer is reading information from the disk into memory. Then while the indicator in drive B is on, the computer is writing that same information onto the tracks and sectors in drive B. When this process has been completed, the computer will show:

Verifying...

Again, the disk access indicators in drive A and drive B will alternately come on. This time, the computer reads the information from each respective disk and then compares the data to make sure it matches. This process verifies that the destination disk is an exact copy of the source disk. When this process has been completed, the computer will show:

Do you wish to copy another disk (Y/N)? <N>

- If you have another disk to duplicate, press the Y key, followed by the **RETURN** key. You will again be asked to enter the name of the drives being used.
- If you do not have any other disks to copy, press the **RETURN** key. The character inside the angle brackets indicates the default value (the character used if you do not enter anything from the keyboard). In this case, the letter N is used as the default value; you could have pressed the N key and then the RETURN key instead.

The computer will display the MS-DOS prompt.

Backups

Using the FORMAT and COPY Procedure to Make Backups

The external FORMAT command is used to organize the surface of a new, unformatted disk and place a copy of the operating system on it to create a bootable disk. The internal COPY command is used to copy or backup your original files.

You must always format new disks, since the COPY command does not automatically format blank disks. It is also necessary to format any disk that was used on a different computer (other than a Z-100 or Z-100 PC under MS-DOS version 2), under a different operating system, or that had been partially or completely erased by a magnetic field. Different computers and operating systems may use a different, incompatible format the disk.

FORMAT

Turn on the computer and boot the MS-DOS disk #1 working copy. The display will show the MS-DOS prompt:

```
A>
```

- If you want to produce a bootable disk, enter the following command line.

```
FORMAT B:/S/V
```

- If you want to produce a data disk, one that is not bootable, enter the following command line.

```
FORMAT B:/V
```

Backups

- Press the **RETURN** key. The `B:` portion of the command line tells the computer that you will use drive B to format the disk. The `/S` tells the format utility to place the operating system on the disk. The `/V` tells the utility to verify each sector on the disk and lock out any that are identified as bad. The computer will display the following information and prompt.

FORMAT version 2.20

Copyright(C) 1984, Zenith Data Systems Corporation

Insert new disk in drive B and press RETURN when ready.

NOTE: The format procedure does not check to see if your disk has data on it. Any information previously recorded on the disk will be erased and blank (empty) tracks will be placed on the disk, making it ready to receive new data. Be sure you are using a blank disk (or one that you wish to erase).

- Place a blank disk in drive B and close the door or latch.
- Press the **RETURN** key. The disk access indicator in drive B will light and you may be able to hear the drive making some quiet clicking sounds as the disk is formatted. When a disk has been formatted that will have the operating system on it, you will see the following message on the screen.

System transferred

After the system has been recorded on the disk or, for a data disk, after it has been formatted, you will see the following prompt on your screen.

Enter desired volume label (11 characters, RETURN for none)?

This is the only place that you can assign a volume name to your disk. Remember that the volume name is displayed by the `CHKDSK` and `VOL` commands.

Backups

Up to 11 characters, consisting of letters, numbers, spaces, underlines, and/or hyphens. All other characters are illegal and if you try to use one of them in your label, the computer will display the following error message.

```
Invalid characters in volume id
```

```
Enter desired volume label (11 characters, RETURN for none)?
```

It is a good idea to enter a volume name (label) that is similar to the label you prepare for the disk. However, be aware that 11 characters are a very limited number of characters that you can use for the name, so carefully plan what you want to enter.

Once a disk has had a name entered onto it, the only way the name can be changed is to reformat the disk.

- Enter the volume name and press the **RETURN** key. The computer will display a report on the amount of disk space used and available. For a system disk formatted with 8 sectors per track, the computer will display the following.

```
322560 bytes total disk space
```

```
50176 bytes used by system
```

```
272384 bytes available on disk
```

For a data disk formatted with 9 sectors per track, the computer will display the following.

```
362496 bytes total disk space 362496 bytes available on disk
```

The computer will prompt you with the following message. It is asking you if you want to format additional disks, using the same parameters (specifications) that you specified in the original command line.

```
Do you wish to format another disk (Y/N)?
```

- Press the Y key if you wish to format another disk using the same disk drive and parameters that you specified in the command line.

Backups

- Otherwise, press the N key if you do not want to format another disk using the same drive or parameters.

The computer will either prompt you to insert a new disk in the specified drive or return you to the MS-DOS prompt. Note that you do not have to press the RETURN key for this prompt.

- Prepare a label for the disk in drive B. For information on labeling disks, refer to Chapter 2 of this manual.

You are now ready to back up your files.

COPY

- Remove the MS-DOS disk #1 working copy from drive A and put it away.
- Take the disk in drive B and place it in drive A.
- Place the disk from which you wish to copy (backup) files in drive B.
- Enter the following command line.

```
COPY B:.* */V
```

- Press the **RETURN** key. The disk access indicators of each drive will alternately come on and the name of each file will be displayed as it is read into memory from the disk in drive B and then written onto the disk in drive A. When all the files have been copied, the computer will display a message similar to the following.

```
xx File(s) copied
```

```
A>
```

The xx in the display will indicate the number of files that were transferred to the disk (in this case, all of them).

Backups

The COPY command is used to copy one or more files from one disk to another. It is a widely used command that can be used to make backups or system disks from software that is distributed on nonsystem disks. The message displayed at the end of the operation tells you how many files were involved in any particular COPY procedure.

Likewise, the COPY command can be used to transfer files from one type of disk to another. For instance, you can copy files from a 5.25-inch distribution disk to either a Winchester partition or an 8-inch floppy disk with the COPY command.

In the next section of this appendix, you will use the FORMAT and COPY commands to create a special operating system disk, one that can be used as the basis for most of your bootable system disks.

Creating Bootable MS-DOS Disks for Your Applications Packages

If you read through chapter two of this manual or have attempted to read the directory of MS-DOS disk #1, you know that it has a branch directory on it that contains the majority of the useful MS-DOS utility programs. However, it is not always convenient to use branch directories on 5.25-inch disks. You may use the following procedure to create a minimum system MS-DOS disk that can be used as a root bootable disk for many of your application programs.

A number of application programs require one or more MS-DOS files and utilities for proper or convenient operation. The files and utilities include ALTCHAR.SYS, CONFIG.SYS, CHKDSK.COM, FORMAT.COM, CONFIGUR.COM, DISKCOPY.COM, PRINT.COM, RDCPM.COM, MAP.COM, and ZDIR.COM. You may not need some of these files; you will be given the opportunity as you create this new MS-DOS disk to select the files you think are necessary to your computer operation.

Backups

- Prepare a label for a new disk. Label it "MS-DOS minimum system disk."
- Boot your computer from MS-DOS disk #1 working copy.
- Place a blank disk in drive B and enter the following command line.

FORMAT B:/V/S

- Press the **RETURN** key. The computer will load the FORMAT utility from drive A and display a message similar to the following:

FORMAT version 2.20

Copyright(C) 1984, Zenith Data Systems Corporation

Insert new disk in drive B and press RETURN when ready.

- Insert the new disk in drive B and close the door or latch.
- Press the **RETURN** key. The computer will format the disk in drive B and lock out any bad sectors. Then it will display the following messages.

System transferred

Enter desired volume label (11 characters, RETURN for none)?

- Enter the following volume label.

MS-DOS

- Press the **RETURN** key. The computer should display the following information.

322560 bytes total disk space

50176 bytes used by system

272384 bytes available on disk

Do you wish to format another disk (Y/N)?

Backups

- ❑ Examine the disk allocation information. If you see any disk space allocated to bad sectors, remove the disk and format a new disk. *Do not use a disk with bad sectors for this procedure.*
- ❑ If the disk does not have bad sectors, press the N key, followed by the **RETURN** key. The MS-DOS prompt will be displayed.
- ❑ Transfer control to drive B by entering the following command line.

B:

- ❑ Press the **RETURN** key. The system prompt should now be B>.

Now you will copy files from the MS-DOS disk #1 working copy in drive A to drive B. For each file, you must choose to copy or not to copy the file to the new MS-DOS minimum system disk.

The first two files that you will copy are the system files, CONFIG.SYS and ALTCHAR.SYS. These files are loaded automatically into memory if they are on the disk when you boot the system. Since they carry important information, such as the graphics characters, it is suggested that you always place these files on your bootable system disks, since they do not occupy much space (less than 1 kilobyte).

- ❑ To copy the two system files, enter the following command line.

COPY *.SYS B:

- ❑ Press the **RETURN** key. The computer will display the following lines as the files are copied.

```
ALTCHAR.SYS  
CONFIG.SYS  
2 File(s) copied
```

Backups

- The following files will be copied from the branch directory, BIN. To change the directory of the disk in drive A, enter the following command line.

```
CD A: BIN
```

- Press the **RETURN** key.

The file CHKDSK.COM is used to check and correct any problems with the directory. It is also used to report free disk space. It can be used by some programs to report this information without leaving the program. Therefore, it should be placed on your system disks.

- To copy CHKDSK.COM, enter the following command line.

```
COPY A:CHKDSK.COM
```

- Press the **RETURN** key. The file will be copied and the computer will report:

```
1 File(s) copied
```

You should be familiar with FORMAT.COM. It is the format utility and is used to format new, blank disks. Since very few application programs have this capability, you should place FORMAT on most of your system disks.

- To copy FORMAT.COM, enter the following command line.

```
COPY A: FORMAT.COM
```

- Press the **RETURN** key.

The CONFIGUR utility is used to configure the operating system on your disks to the characteristics of your computer system. Although this utility may be left off the minimum system disk, it occasionally is needed if you have more than one Z-100 system, frequently change peripherals in the system you do have, or expect to make changes in the near future.

Backups

- ❑ To copy CONFIGUR.COM, enter the following command line.

```
COPY A:CONFIGUR.COM
```

- ❑ Press the **RETURN** key.

The DISKCOPY utility can be used to make exact duplicates of your disks. If you have two 5.25-inch or two 8-inch floppy disk drives, you will want this utility on your minimum system disk. If you have a Winchester system and a single floppy disk drive, then do not copy this file.

- ❑ To copy DISKCOPY.COM, enter the following command line.

```
COPY A:DISKCOPY.COM
```

- ❑ Press the **RETURN** key.

The PRINT utility is used to print files in the background mode. This means that you can use the computer to print files at the same time you are using it to do other tasks. Copy this file only if you expect to need this function. Most word processing programs, including MicroPro's WordStar® and Microsoft's Word, have this capability.

- ❑ To copy PRINT.COM, enter the following command line.

```
COPY A:PRINT.COM
```

- ❑ Press the **RETURN** key.

The RDCPM utility is used to copy files from CP/M disks. If you do not have CP/M disks to copy, do not include this file. If you will be using CP/M-85 or CP/M-86 on your Z-100, you may need to occasionally use this utility.

Backups

- To copy RDCPM.COM, enter the following command line.

```
COPY A:RDCPM.COM
```

- Press the **RETURN** key.

The MAP utility is required by some application programs to properly map the drive names when the Winchester or 8-inch disk drives are used. Copy this file to your minimum system disk only if you have a Winchester disk drive or 8-inch floppy disk drives.

- To copy MAP.COM, enter the following command line.

```
COPY A:MAP.COM
```

- Press the **RETURN** key.

The ZDIR utility is a modified directory utility that displays the directory entries in alphabetical order. You use this directory command most often when you have disks that have a large number of files.

- To copy ZDIR.COM, enter the following command line.

```
COPY A:ZDIR.COM
```

- Press the **RETURN** key.

You have copied all of the files that are needed on a regular basis with MS-DOS. You may find others equally important to your particular system. Copy those files at this time, using the same procedure.

If you plan to use the screen dump facility, refer to your MS-DOS documentation and copy the appropriate file from the PSC branch directory of MS-DOS disk #2.

Backups

If you copied the files suggested in this section, taking a directory of drive B should produce a display similar to the following.

Volume in drive B is MS-DOS Directory of B:\

COMMAND	COM	16421	11-12-84	11:03a
ALTCHAR	SYS	432	4-04-84	3:18p
CONFIG	SYS	12	9-06-84	2:36p
CHKDSK	COM	6468	4-04-84	1:47p
FORMAT	COM	13674	11-12-84	11:42a
CONFIGUR	COM	12031	11-12-84	11:47a
DISKCOPY	COM	15738	11-12-84	11:35a
PRINT	COM	6288	10-31-84	12:52p
RDCPM	COM	3818	11-12-84	11:33a
MAP	COM	3743	10-26-84	1:23p
ZDIR	COM	3372	6-01-84	2:58p
11 File(s)		200704 bytes free		

An absolute minimum MS-DOS disk would produce a directory similar to the following.

Volume in drive B is MS-DOS Directory of B:\

COMMAND	COM	16421	11-12-84	11:03a
ALTCHAR	SYS	432	4-04-84	3:18p
CONFIG	SYS	12	9-06-84	2:36p
CHKDSK	COM	6468	4-04-84	1:47p
FORMAT	COM	13674	11-12-84	11:42a
5 File(s)		2xxxxx bytes free		

The advantage to keeping the number of files to an absolute minimum is that your system disk can hold more application programs. One alternative to obtaining slightly more disk space is to format the system disk with the /9 switch, thus recording 9 sectors per track instead of 8. This higher density will sometimes reduce the reliability of a system operated under adverse conditions and makes the system somewhat more sensitive to rapid variations of temperature and/or humidity. If your system will be operated in a

Backups

location where the temperature and humidity are relatively stable (such as in an air conditioned office), then you should experience no problems using disks that are formatted to the higher density.

- Use DISKCOPY to produce two copies of the minimum system disk to use as working copies. Label them appropriately.
- Whenever you want to produce a system disk for an application program, use DISKCOPY to produce a new copy of the minimum system disk. Then copy your application files to the new minimum system disk and label it accordingly.

If you plan to go through the exercises in Chapter 3 of this manual, you will want to place a copy of the BASIC interpreter on a bootable disk. Use DISKCOPY to produce a copy of the minimum system disk and then follow the directions provided in Chapter 3 to produce a bootable BASIC disk.

- 25th line
 - disable, B-13
 - display, E-1
 - enable, B-12
 - transmit, B-14
- 8085, H-1
- 8088, H-1

- A
- Acoustic coupler, A-1
- Acronym, A-1
- Address, A-1
- Algebra
 - Boolean, A-3
- Algorithm, A-1
- Alpha, A-1
- Alphanumeric, A-1
- Alternate keypad mode, B-11
- ALU, A-1
- ANSI, A-1
- Application, A-1
- Application program, A-2
- Argument, A-2
- Array, A-2
- Arrow keys, 1-11
- Artificial intelligence, A-2
- ASCII, A-2
 - character set, B-2
- Assemble, A-2
- Assembler, 3-3, A-2
- Assembly language, A-2
- Asynchronous, A-2
- Autoboot, 2-2, G-23
- Automatic key repeat, H-3
- AUX, F-3

- B
- BACKSPACE key, 1-10
- Backup, A-2
- Backups, 2-8, 2-11, K-13
- Bar
 - space, 1-10
- BASIC, 3-4, A-2; *see also* GW-BASIC, Z-BASIC
 - arithmetic operators, E-3
 - arrays, E-4
 - color attributes, E-4
 - command summary, E-1, E-5
 - control characters, E-1
 - copyright notice, 1-21
 - designing a program, 3-15
 - display 25th line, E-1
 - double-precision, E-2
 - END, 3-13, 3-22
 - error message, 3-9
 - FILES, 3-14, 3-15
 - getting started, 3-6
 - GOTO, 3-22, 3-23
 - hexadecimal prefix, E-2
 - IF ... THEN, 3-22, 3-23
 - INPUT, 3-12
 - integer, E-2
 - LIST, 3-13
 - LOAD, 3-14
 - loading, 3-7
 - logical operators, E-3
 - mode -direct, 3-8, 3-9
 - mode-indirect, 3-8, 3-12
 - modes of operation, 3-8
 - NEW, 3-19
 - octal prefix, E-2
 - PRINT, 3-9, 3-10
 - PRINT solution, 3-24
 - PRINT USING, 3-24
 - programming in, 3-12
 - relational operators, E-3
 - resume program execution, E-2
 - RUN, 3-13, 3-15
 - sample output, 3-24
 - SAVE, 3-14
 - saving and loading programs, 3-14
 - single-precision, E-2
 - statements, 3-9
 - stop program execution, E-1
 - string, E-2
 - string operators, E-4
 - SYSTEM, 3-15
 - truth table for logical operators, E-4
 - understanding, 3-6
 - variable specifications, E-2
 - variable types, 3-11
 - variables, 3-11
- BASIC-80, 2-1
- Batch processing, A-3
- Baud rate, A-3, F-14
 - modify, B-12
- BCD, A-3
- Beep speaker, E-1
- Binary, A-3
- Bit, A-3
- Bit density, A-3
- Bits per word, F-16
- Block
 - indicator (cursor), 1-10
- Block diagram, A-3

- Board, A-3
- Boolean algebra, A-3
- Boot, 2-2, A-3, G-23
- Bootstrap, A-3
- Branch, A-3
- Break, A-4
- BREAK key, 1-11
- Buffer, A-4,
- Bug, A-4
- Bus, A-4
 - type, H-2
- Byte, A-4

- C**
- Cable, A-4
- Capacity
 - floppy disk, 1-2
- Card, A-4
- CBASIC, J-13
- Centronics, A-4
 - type connector, 1-5 Character, A-4
 - set, H-2
 - size, H-2
 - type, H-2
- Checksum, A-4
- Chip, A-4
- Circuit, A-5
- Clear display (move cursor home), B-11
- CLS, E-1
- COBOL, 3-4, A-5
- Code, A-5
- Codes
 - ASCII function key (key expansion enabled), B-10
 - ASCII keypad (key expansion enabled), B-9
 - escape - additional functions, B-14
 - escape -configuration, B-12
 - escape - cursor function, B-10
 - escape-erasing and editing, B-11
 - escape - modes of operation, B-11
 - hexadecimal key, B-5
- Colors, H-2
 - set foreground and background, B-14
- Command, A-5
- Communications, A-5 DCE, 1-5
 - DTE, 1-5
 - RS-232, 1-5
 - telephone, 1-2
- Compile, A-5
- Compiler, 3-4, A-5

- Composite video, A-5
- Computer, A-5
 - default answer 2-16
 - digital, A-7
 - entering information, 1-2
 - environment, 1-2
 - fan, 1-3, 1-7
 - "hang up", 2-18
 - identify as a VT52 terminal, B-14
 - identify as a Zenith terminal, B-14
 - installation, 1-2
 - location, 1-2
 - maintaining proper ventilation, 1-3
 - peripherals, 1-1
 - power up, 1-19
 - reset, 1-11, E-2
 - reset configuration, B-13
 - specifications, G-29
 - system, 1-1
 - typical system, 1-1
 - uses of, 1-1
 - ventilation, 1-7
- CON, F-3
- Connectors
- Centronics-type printer, 1-5
 - DCE, 1-5
 - DTE, 1-5
 - J1, 1-5
 - J15, 1-3
 - J2, 1-5
 - J3, 1-5
 - J4, 1-5
 - J9, 1-3, G-26
 - J9 (RGB) pinout, G-26
 - light pen, 1-5
 - modem, 1-5
 - parallel, 1-5
 - parallel printer, 1-5
 - power, 1-7
 - power cord, 1-6, 1-7
 - printer, 1-5
 - RGB, G-26
 - serial, 1-5
 - unused, 1-3
- Control
 - brightness, 1-3
- Control keys, 1-12, 2-17
 - combination, 1-12
 - operation, how to perform, 1-12
- Conversion
 - Z-89 to Z-100, J-1

Copies

- working, 2-8
- COPY, 2-1, 2-23
- CP/M, 2-1, A-6, L-12
- CP/M-80, J-1
- CP/M-85, 2-1
 - ;,1-6
 - ASM, 1-2
 - ASSIGN, 1-2
 - BACK SPACE, 1-1
 - BACKUP, 1-2
 - BSYSGEN, 1-6
 - CONFIGUR, 1-3
 - CTRL-C, I-1
 - CTRL-E, I-1
 - CTRL-L, I-1
 - CTRL-P, I-1
 - CTRL-R, I-1
 - CTRL-S, I-1
 - CTRL-U, I-1
 - CTRL-X, I-1
 - CTRL-Z, I-1
 - DDT, 1-3
 - DIR, 1-3
 - DUMP, 1-6
 - DUP, 1-4
 - ED, 1-4
 - ERA, 1-3
 - FORMAT, 1-4
 - LINE FEED, I-1
 - LIST, 1-6
 - LOAD, 1-4,1-5
 - MVCPM207/217, 1-5
 - PIP, 1-3
 - PREL, 1-4
 - REN, 1-6
 - RESTORE, 1-6
 - RETURN, I-1
 - SAVE, 1-6
 - STAT, 1-3,1-5
 - SUBMIT, 1-2
 - SYSGEN, 1-6
 - TAB, 1-1
 - USR, 1-2,1-5
 - XSUB, 1-2
- CPS, A-6
- CPU, A-6
- Crash, A-6
- CRT, 1-2, A-6, H-2
- CTRL key, 1-12

Cursor, 1-10, A-6

- delete word at cursor position, E-2
- direct addressing, B-10
- disable, B-12
- enable, B-13
- enable blinking, B-13
- enable block, B-12
- enable solid (non-blinking), B-12
- enable underscore, B-13
- move down, B-10, E-2
- move home, B-10
- move left, B-10, E-2
- move one word to left, E-1
- move one word to right, E-1
- move right, B-10, E-2
- move to end of program line, E-1
- move to last saved position, B-10
- move up, B-10, E-2
- movement (arrow keys), 1-11
- return position report, B-10
- save current position, B-10
- turn off, B-12
- turn on, B-13

Cylinder, A-6

D

- Daisy wheel printer, A-6
- Data, A-6
- Data base, A-6
- Data processing, A-6
- DataStar, J-12
- DCE, A-6
- DCE connector, 1-5
- Debug, A-7
- Decimal, A-7
- Default, 2-16
- Default boot device, G-23
- Delete, A-7
 - word at cursor position, E-2
- DELETE key, 1-11
- Delete line, B-11
- Deletion keys, 1-11
- Demonstration disk, 1-20
 - artwork display, 1-22
 - business graphics, 1-23
 - continuous demonstration, 1-25
 - exiting, 1-22
 - freezing display, 1-23
 - interactive business graphics, 1-23
 - master menu, 1-22
 - types of charts, 1-24
 - using, 1-20

- Density, A-7
 - bit, A-3
 - double, A-8
 - single, A-18
- Descenders, A-7
- Despool, J-13
- Device, A-7
- Diablo
 - 1640, F-1
 - 620, F-1
 - 630, F-1
- Digit, A-7
- Digital computer, A-7
- Direct access, A-17
- Direct-connect modem, A-7
- Directories, A-7
 - branch, 2-28
 - dot and dot-dot, 2-30
 - "getting", 2-24
 - paths, 2-10, 2-30
 - root, 2-28
- Disable
 - 25th line, B-13
 - automatic CR on LF, B-13
 - automatic LF on CR, B-13
 - cursor, B-12
 - event-driven mode, B-13
 - key click, B-12
 - key expansion mode, B-13
 - keyboard, B-14
 - keyboard automatic repeat, B-12
 - wraparound at end of line, B-14
- Disassembly, G-1
- Disk, 1-15, A-7
 - demonstration, 1-20
 - system, 2-40
 - utilities, 2-36
 - volume name, 2-35
 - Winchester, 1-2
- Disk drives, 1-13, A-8
 - A, 1-13
 - B, 1-13
 - default, 2-11
 - disk access indicator, 1-14
 - disk load slot, 1-14
 - latch, 1-14
 - names, 1-13, 2-21
 - positions, 1-13
 - read/write heads, 1-14
 - step rates, F-7
 - single, 1-13
 - types, 1-13
 - Winchester, 1-15
- Disk operating system, A-8; *see also* DOS
- Diskette, 1-15, A-8
- Disks; *see* Floppy disk, 2-12
- Display, A-8
 - 25th line, E-1
 - format, H-2
 - monochrome, A-14
 - next program line, E-2
 - pages, H-2
 - previous program line, E-2
 - size, H-2
 - video, 1-1, 1-2
- DOS, 1-13, 1-16, 2-1, A-8
- Dot resolution, H-2
- Dot-matrix printer, A-8
- Double-density, A-8
- DS1 switch settings, G-25
- DTE, A-8
- DTE connector, 1-5

- E**
- EBCDIC, A-8
- Edit, A-8
- EEPROM, A-8
- EIA standard, 1-5
- Enable
 - 25th line, B-12
 - automatic CR on LF, B-12
 - automatic LF on CR, B-12
 - blinking cursor, B-13
 - block cursor, B-12
 - cursor, B-13
 - event-driven mode, B-12
 - key click, B-13
 - key expansion mode, B-12
 - keyboard, B-14
 - keyboard automatic repeat, B-13
 - solid (non-blinking) cursor, B-12
 - underscore cursor, B-13
 - wraparound at end of line, B-14
- Enter
 - alternate keypad mode, B-11, B-12
 - graphics mode, B-11
 - hold screen mode, B-12
 - insert character mode, B-11
 - keypad shifted mode, B-11, B-12
 - reverse video mode, B-11
- ENTER key, 1-12

- Entry
 - (for calculator keypad--page 12), 1-12
 - data, 1-10
 - instruction completed, 1-10
 - repeated key, 1-12
- EPROM, A-9
- Epson
 - MX-80, F-1
- Erase
 - current line, B-11
 - display, E-1
 - display (move cursor home), B-11
 - to beginning of display, B-11
 - to beginning of line, B-11
 - to end of line, B-11, E-1
 - to end of page, B-11
 - to end of screen, E-2
- ESC key, 1-12
- Escape key, 1-12
- Escape sequence
 - how to perform, 1-12
- Execute, A-9
- Exit
 - alternate keypad mode, B-11, B-13
 - graphics mode, B-11
 - hold screen mode, B-13
 - insert character mode, B-11
 - keypad shifted mode, B-11
 - reverse video mode, B-11
 - shifted keypad mode, B-13
- Extension, 2-21
- F**
- Fan, 1-3
- Fast key repeat, H-3
- FAST REPEAT key, 1-12
- FCC
 - Class A, A-5
 - Class B, A-5
- Field, A-9
- File, A-9, 2-21
 - command, 2-19
 - extension, 2-21
 - hidden, 2-21
 - names, 2-21
 - read after write, 2-35
 - specification, 2-21
 - verification, 2-35
- Firmware, A-9
- Floppy disk
 - 5.25-inch, 1-2, H-4
 - 8-inch, 1-2, H-4
 - bending (don't), 1-18
 - Floppy disk (continued)
 - capacity, H-4
 - care, 1-15, 1-18
 - controller board switch DS1, G-25
 - damage, 1-16, 1-18
 - data transfer, H-4
 - default drive, 2-11
 - demonstration disk, 1-20
 - density, 1-17
 - destination, 2-12
 - disk, 1-15
 - disk access indicator, 1-19
 - drive name, 2-21
 - envelope, 1-15
 - fingerprints, 1-16
 - format, 1-16
 - handling, 1-18
 - hard-sector, 1-17
 - heat (don't), 1-18
 - jacket, 1-15
 - labeling, 1-18, 2-14
 - magnetized objects (don't), 1-19
 - Mylar, 1-15
 - number of sides, 1-18
 - number of tracks per inch, 1-18
 - numbering, 2-15
 - openings, 1-16
 - paper clips (don't), 1-18
 - parts of, 1-15
 - precompensation, H-4
 - protective liner, 1-15
 - read/write head slot, 1-16
 - reading, 2-8
 - recording, 1-16
 - sectoring, 1-17
 - soft-sector, 1-17
 - source, 2-12
 - specifications, H-4
 - sunlight (don't), 1-18
 - timing hole, 1-16
 - tpi, 1-18
 - volume name, 2-35,2-41
 - write-enable notch, 1-16
 - write-protect notch, 1-16
 - X-rays (caution), 1-19
- Flowchart, A-9
- FORMAT, 2-1
 - floppy disk, 1-16
- Formatting, A-9
- FORTRAN, 3-4, A-9
- Function keys
 - using (demonstration program), 1-22,1-25

G

General Ledger II, J-11
 Graphics, A-9
 Graphics mode, B-11
 Gray scale, H-2
 GW-BASIC, 2-1, 3-7, K-1; *see also*
 BASIC, E-2
 ABS, E-5
 AND, E-3
 arrays, E-4
 ASC, E-5
 ATN, E-5
 AUTO, E-5
 BACK SPACE, E-2
 BEEP, E-5
 BLOAD, E-5
 BSAVE, E-5
 CALL, E-5
 CDBL, E-5
 CHAIN, E-5
 CHDIR, E-6
 CHR\$, E-6
 CINT, E-6
 CIRCLE, E-6
 CLEAR, E-6
 CLOSE, E-6
 CLS, E-1, E-6
 COLOR, E-6
 COM, E-6
 COMMON, E-6
 CONT, E-7
 COS, E-7
 CSNG, E-7
 CSRLIN, E-7
 CTRL-B, E-1
 CTRL-C, E-1
 CTRL-E, E-1
 CTRL-F, E-1
 CTRL-G, E-1
 CTRL-H, E-1
 CTRL-I, E-1
 CTRL-J, E-1
 CTRL-L, E-1
 CTRL-M, E-1
 CTRL-N, E-1
 CTRL-P, E-1
 CTRL-Q, E-2
 CTRL-R, E-1
 CTRL-RESET, E-2
 CTRL-S, E-1
 CTRL-T, E-1
 CTRL-W, E-2
 CTRL-X, E-2
 CTRL-Y, E-2
 CTRL-Z, E-2
 CVD, E-7
 CVI, E-7
 CVS, E-7
 DATA, E-7
 DATE\$, E-7
 DEF FN, E-7
 DEF SEG, E-8
 DEF USR, E-8
 DEFDBL, E-8
 DEFINT, E-8
 DEFSNG, E-8
 DEFSTR, E-8
 DEL, E-2
 DELETE, E-8
 DIM, E-8
 display next program line, E-2
 display previous program line, E-2
 DRAW, E-8
 EDIT, E-9
 ELSE, E-9
 END, E-9
 ENVIRON, E-9
 ENVIRON\$, E-9
 EOF, E-10
 EQV, E-3
 ERASE, E-10
 ERDEV, E-10
 ERDEV\$, E-10
 ERL, E-10
 ERR, E-10
 ERROR, E-10
 EXP, E-10
 FIELD, E-10
 FILES, E-10
 FIX, E-10
 FOR ... TO ... NEXT, E-10
 FRE, E-1 1
 GET, E-1 1
 GOSUB, E-1 1
 GOTO, E-1 1
 HEX\$, E-11
 HOME, E-2
 IF...THEN...ELSE, E-1 1
 IMP, E-3
 IN KEY\$, E-1 1
 INP, E-11
 INPUT, E-11
 INPUT #, E-1 1
 INPUT\$, E-1 1
 INS, E-2

INSTR, E-12
INT, E-12
IOCTL, E-12
IOCTL\$, E-12
KEY, E-12
KILL, E-12
LEFT\$, E-12
LEN, E-12
LET, E-12
LINE, E-12
LINE INPUT, E-12
LINE INPUT #, E-13
LIST, E-13
LUST, E-13
LOAD, E-13
LOC, E-13
LOCATE, E-13
LOF, E-13
LOG, E-13
LPOS, E-13
LPRINT, E-13
LPRINT USING, E-13
LSET, E-13
MERGE, E-13
MID\$, E-14
MKD\$, E-14
MKDIR, E-14
MKI\$, E-14
MK\$, E-14
NAME, E-14
NEW, E-14
NOT, E-3
NULL, E-14
OCT\$, E-14
ON COM, E-14
ON ERROR, E-15
ON KEY, E-15
ON PEN, E-15
ON TIMER, E-15
ON ...GOSUB, E-15
ON ...GOTO, E-15
OPEN, E-15
OPTION BASE, E-15
OR, E-3
OUT, E-15
PAINT, E-15
PEEK, E-16
PEN, E-16
PEN ON..., E-16
PMAP, E-16
POINT, E-16
POKE, E-16
POS, E-16
PRESET, E-16
PRINT, E-16
PRINT #, E-17
PRINT USING, E-16
PSET, E-17
PUT, E-17
PUT #, E-17
RANDOMIZE, E-18
READ, E-18
REM, E-18
RENUM, E-18
RESET, E-18
RESTORE, E-18
RESUME, E-19
RETURN, E-1, E-19
RIGHT\$, E-19
RMDIR, E-19
RND, E-19
RSET, E-19
RUN, E-19
SAVE, E-19
SCREEN, E-19, E-20
SGN, E-20
SHELL, E-20
SIN, E-20
SPACE\$, E-20
SPC, E-20
SQR, E-20
STOP, E-20
STR\$, E-20
STRING\$, E-20
SWAP, E-20
SYSTEM, E-21
TAB, E-2, E-21
TAN, E-21
THEN..., E-21
TIMES\$, E-21
TIMER, E-21
toggle insert mode on/off, E-1
toggle printer on/off, E-1
TOKEN, K-1
TROFF, E-21
TRON, E-21
USING specifiers, E-17
USR, E-21
VAL, E-21
VARPTR, E-22
VARPTR\$, E-22
VIEW, E-22
VIEW PRINT, E-22

WAIT, E-22
 WEND, E-22
 WHILE, E-22
 WIDTH, E-22
 WINDOW, E-22
 WRITE, E-22
 WRITE #, E-22 XOR, E-3

H

Handshaking, F-15
 Hard copy, A-9
 Hard-sectored, A-9
 Hardware, A-9
 Heath
 H-125, F-1
 H-14, F-1
 H-25, F-1
 WH-12, F-1
 WH-23, F-1
 WH-24, F-1
 WH-33, F-1
 WH-34, F-1
 HELP key, 1-11
 Hexadecimal, A-10
 Hidden file, A-10
 High-level language, A-10
 Home, A-10
 HOME key, 1-11
 using (demonstration disk), 1-25
 Humidity range, 1-2

I

I/O A-10
 IO A-10
 In case of difficulty, 1-26
 Index
 reverse, B-10
 Indicator
 block, 1-10
 cursor, 1-10
 disk access, 1-14,1-19
 underline, 1-10
 Ink jet printer, A-10
 Input, A-10
 Input'Output, A-10
 specifications, H-5
 Insert line, B-11
 Insertion keys, 1-11
 Installation, 1-2
 Instruction, A-10

Integer, A-10
 Interactive Business Graphics
 create new data file, K-3
 data management routines, K-3
 displaying the graph, K-12
 graphic design routine, K-8
 modify existing data file, K-6
 print existing data file, K-8
 Interactive processing, A-10
 Interface, A-10
 Centronics, A-4
 RS-232, A-18
 Interlace, H-2
 Interpreter, 3-4, A-11
 Interrupt, A-11
 program control, E-1

J

J301, G-27
 J302, G-27
 J303, G-27
 J304, G-27
 J305, G-28
 J306, G-28
 J307, G-28
 Jump, A-11
 Justify, A-11

K

K, A-11
 Key
 CAPS LOCK, 1-8
 Key click, H-3
 enable, B-13
 disable, B-12
 Keyboard, 1-1, 1-8, A-11
 Keypad
 numeric, 1-2,1-12
 Keypad shifted mode, B-11
 Keys
 alphabetic, 1-8
 arrow, 1-11
 BACK SPACE, 1-10, 2-17, D-1, E-1, E-2, I-1
 BREAK, 1-11
 click, H-3
 control, 2-17
 CTRL, 1-12,2-2
 CTRL-A, E-1
 CTRL-B, E-1
 CTRL-C, 2-18, D-1, E-1, I-1
 CTRL-DELETE, 2-2
 CTRL-E, E-1, I-1

- CTRL-F, E-1
- CTRL-G, E-1
- CTRL-H, E-1
- CTRL-I, E-1
- CTRL-J, E-1
- CTRL-L, E-1, I-1
- CTRL-M, E-1
- CTRL-N, 2-19, D-1, E-1, I-1
- CTRL-P, 2-18, D-1, E-1, I-1
- CTRL-Q, E-2
- CTRL-R, E-1, I-1
- CTRL-RESET, E-2
- CTRL-S, using (demo disk), 1-23, 2-18, D-1, E-1, I-1
- CTRL-T, E-1
- CTRL-U, E-2, I-1
- CTRL-W, E-2
- CTRL-X, 2-17, D-1, E-2, I-1
- CTRL-Y, E-2
- CTRL-Z, E-2, I-1
- cursor movement, 1-11
- D CHR, 1-11, E-2
- debounce, H-3
- DEL, E-2
- DEL LINE, 1-11
- DELETE, 1-11, 1-19, 2-2, E-2
- deletion, 1-11
- ENTER, 1-12
- ESC, 1-12
- F0 through F12, 1-11
- FAST REPEAT, 1-12
- function, 1-11
- HELP, 1-11, 2-6
- HOME, 1-11, E-2
- I CHR, 1-11, E-2
- INS, E-2
- INS LINE, 1-11, E-1
 - insertion, 1-11
- LINE FEED, 1-11, 2-17, D-1, E-1, I-1
- minus (in keypad), 1-12
- nonalphabetic, 1-9
- number of, 1-8
- numeric, 1-9
- numeric (in keypad), 1-12
- period (in keypad), 1-12
- punctuation, 1-9 repeat, H-3
- RESET, 1-11
- RETURN, 1-10, 2-17, D-1, E-1, I-1
- space bar, 1-10
- special characters, 1-9
- TAB, 1-10, D-1, E-1, E-2, I-1
- Keyword, A-11
- Kilo, A-11
- Kilobit, A-11
- Kilobyte, A-12
- L
- Language, A-12
 - assembly, 3-3, A-2
 - comparison, 3-5
 - high-level, 3-3, A-10
 - machine, 3-3, A-12
 - program, A-16
 - programming, 3-2
 - types, 3-3
- Light pen, H-2
 - connector, 1-5
- Line
 - delete, B-11
 - insert, B-11
 - logical, A-12
 - physical, A-15
- LINE FEED key, 1-11
- Line select switch, 1-6, 1-7
- Load, A-12
- Location
 - computer system, 1-2
- Logical line, A-12
- M
- M, A-12
- Machine language, A-12
- Macro Assembler, J-13
- MACRO-80, J-13
- Magic Wand, J-12
- MailMerge, J-12
- Mainframe, A-12
- Maintenance, A-12
- Mapping lowercase to uppercase, F-12
- Matrix, A-13
- Mega, A-13
- Megabyte, A-13
- Memory, A-13, H-1
- Message
 - "autoexe1", 1-22, 1-23
 - "Boot Abort", 1-19, 2-2
 - "Device Error", 1-19, 2-2
 - error, 1-19, 2-20
 - "No system", 2-39
 - "Syntax error", 3-9
 - "zbasic choice", 1-21
 - "zbasicf", 1-22
 - "zbasic menu", 1-23

- Microcomputer, A-13
- Microstat, J-12
- Minicomputer, A-13
- Mnemonic, A-13
- Mode, A-13
- Modem, 1-1, A-1, A-7, A-13
 - acoustic coupler, A-1
 - connector, 1-5
 - direct-connect, A-7
- Modulus, A-13
- Monitor, 1-2, A-13
 - black and white, 1-3
 - boot command, 2-2, 2-3, 2-4, C-1, C-2
 - color, 1-3
 - color bar command, 2-3, 2-5, C-1, C-4
 - command summary, 2-3
 - dump command, 2-3, C-1, C-4
 - examine command, 2-3, C-1, C-5
 - execute command, 2-3, C-1, C-8
 - fill command, 2-3, C-1, C-5
 - help command, 2-3, 2-6, C-1, C-6
 - input command, 2-3, C-1, C-6
 - monochrome, 1-3
 - output command, 2-3, C-1, C-6
 - program, 2-1
 - program commands, C-2
 - prompt, 2-2
 - system command, 2-3, 2-7, C-1, C-7
 - test command, 2-3, C-1, C-7
 - version command, 2-3, 2-7, C-1, C-8
- Monochrome display, A-14
- Mouse, A-14
- MS-DOS, 2-1, 2-16
 - BAT, D-2,1-2
 - APPLY, 2-37, D-2,1-2
 - ASSIGN, 2-37, D-2,1-2
 - BACK SPACE, I-1
 - BACKUP, 2-37, D-2,1-2
 - batch file, D-2,1-2
 - batch processing, D-2,1-2
 - BREAK, 2-22, D-2,1-2
 - CD, 2-22, 2-28, D-2,1-2
 - changing prompts, 2-19
 - CHDIR, 2-22, D-3,1-2
 - CHKDSK, 2-37, 2-38, D-3,1-3, L-5, L-11
 - CIPHER, 2-37, D-3,1-3
 - CLS, 2-22, D-3,1-3
 - COMMAND, 2-37, D-3,1-3
 - command summary, D-1
 - commands, 2-19
 - CONFIGUR, 2-37, 2-47, D-3, E-23, F-2,1-3, L-11
 - control key functions, D-1
 - COPY, 2-22, 2-23, D-3,1-3, L-7
 - creating a minimum system disk, L-8
 - CREF, D-3,1-3
 - CTRL-C, I-1
 - CTRL-N, I-1
 - CTRL-P, I-1
 - CTRL-S, I-1
 - CTRL-X, I-1
 - CTTY, 2-22, D-3,1-3
 - date, 2-9, 2-22, 2-24, D-3,1-3
 - DEBUG, 2-37, D-3,1-3
 - DEL, 2-22, 2-32, D-4,1-3
 - DIR, 2-22, 2-24, D-4,1-3
 - DISKCOMP, 2-37, 2-45, D-4,1-4
 - DISKCOPY, 2-37, 2-43, D-4,1-4, K-13, L-12, L-15
 - DISKCOPY command, 2-12
 - ECHO, 2-22, D-4,1-4
 - EDLIN, 2-37, D-4,1-4
 - ERASE, 2-22, 2-32, D-4,1-3
 - error messages, 2-21
 - EXE2BIN, 2-37, D-4,1-4
 - EXIT, 2-22, D-4,1-4
 - external commands, 2-19, 2-36
 - factor configuration, F-3 FC, 2-37, D-4,1-4
 - file name conventions, D-1
 - filename.BAT, 2-22
 - FIND, 2-37, D-5,1-4
 - FONT, 2-37, D-5,1-4
 - FOR, 2-22
 - for single disk drives, D-8
 - FOR ... IN ... DO, D-5,1-4
 - FORMAT, 2-37, 2-39, D-5,1-4, L-4, L-11
 - FORMAT switches, 2-40
 - GOTO, 2-22, D-5
 - GOTO..., 1-4
 - IF, 2-22, D-5,1-4
 - internal commands, 2-19
 - LIB, 2-37, D-5,1-4
 - LINE FEED, I-1
 - LINK, 2-37, D-5,1-4
 - loading, 2-8
 - MAP, 2-37, 2-47, D-5,1-5, L-13
 - MASM, 1-2
 - MD, 2-22, D-6,1-5
 - minimum, L-14
 - minimum system advantage, L-14
 - MKDIR, 2-22, D-6,1-5
 - MORE, 2-37, D-6,1-5
 - multiple directories, 2-27
 - PATH, 2-22, D-6,1-5
 - PAUSE, 2-22, D-6,1-5

- PRINT, 2-37, D-6,1-5, L-12
- prompt, 2-11, 2-22, D-6,1-5
- prompts, 2-19
- PSC, 2-37, D-6,1-5, L-13
- RD, 2-22, D-7,1-6
- RDCPM, 2-37, D-6,1-6, L-12
- RECOVER, 2-37, D-6,1-6
- REM, 2-22, D-7,1-6
- REN, 2-22,2-33, D-7,1-6
- RENAME, 2-22,2-33, D-7,1-6
- RESTORE, 2-37, D-7,1-6
- RETURN, 1-1
- RMDIR, 2-22, D-7,1-6
- SEARCH, 2-37, D-7,1-6
- SET, 2-22, D-7,1-6
- SHIFT, 2-22, D-8,1-6
- SORT, 2-37, D-8,1-6
- SYS, 2-37,2-43, D-8,1-6
- system files, L-10
- TAB, I-1
- time, 2-9,2-10,2-22,2-33, D-8,1-6
- TYPE, 2-22,2-34, D-8,1-6
- VER, 2-22,2-34, D-8,1-6
- VERIFY, 2-22, 2-35, D-8,1-7
- VOL, 2-22,2-35, D-8,1-7, L-5
- volume name, 2-41
- ZDIR, L-13
- Multiprocessing, A-14
- Multitasking, A-14

- N**
- Network, A-14
- Numbers
 - rounding, 3-23
- Numeric, A-14
 - keypad, 1-12

- O**
- On off power switch, 1-6
- Operating systems, 1-13
- Operation, A-14
- Operator, A-15
- OS, A-14
- Output, A-15
 - color video, 1-3
 - composite monochrome video, 1-3
 - RGB color video, 1-3

- P**
- Pad characters, F-13

- Parallel, A-15
 - connector, 1-5
 - output, H-5
- Parameter, A-15, 2-45
- Parity, A-15, F-12, F-16
- Pearl III, J-14
- Pen; see Light, Pen
- Peripheral, 1-1, A-15
- Physical line, A-15
- Port, A-15
- Power cord
 - connector, 1-6
- Power supply specifications, H-5
- Power switch, 1-19
- Precision, A-15
- Printer, A-16
 - configuration, F-17
 - connector, 1-5
 - daisy wheel, A-6
 - dot-matrix, A-8
 - Ink jet, A-10
 - thermal, A-19
 - uses for, 1-2
- PRN, F-3
- Problem, A-16
 - dim screen (not bright enough), 1-27
 - disk won't boot (autoboot off), 1-27
 - disk won't boot (autoboot on), 1-28
 - no power, 1-26
 - no video (blank screen), 1-27
 - system reboots when not wanted, 1-28
 - system resets when not wanted, 1-28
- Process, A-16
- Processing
 - interactive, A-10
 - word, A-20
- Processor, A-16
- Program, A-16
 - demonstration disk, K-1
 - Interactive Business Graphics, K-1
 - language, A-16
- Programmer, A-16
- Programmers, 3-2
- Programming
 - breakdown, 3-16, 3-17
 - conversion, 3-16, 3-19
 - detailed steps, 3-16, 3-17
 - five steps of design, 3-16
 - languages, 3-2
 - purpose, 3-16
 - testing, 3-16

Programs, 2-21, 3-1; *see also* Software types, 3-1
 PROM, A-16
 Prompt, 2-2, A-16
 from help key, 1-11
 hand, 1-19
 operator aid, 1-11
 Pseudo, A-16
 Pseudo-compiler, 3-4

Q

Queue, A-16
 Qume
 Sprint 11, F-1

R

RAM, A-17
 Random access, A-17
 Read, A-17
 Read/write head, A-17
 function, 1-16
 Real time clock, A-17
 Reassembly, G-12
 Relative humidity range, 1-2
 Repeat last line entered, E-1
 Requirements
 Low-Profile video, 1-3
 Reset, A-17
 Reset Computer, 1-11
 Reset configuration to power-up state, B-13
 RESET key, 1-11
 Resolution
 dot, H-2
 RETURN key, 1-10
 Reverse video mode, B-11
 RGB connector, G-26
 RGB video, A-17 ROM, A-17
 Rounding numbers, 3-23
 Routine, A-17 RS-232
 specifications, H-5
 RS-232 interface, A-18

S

S101 switch settings, G-23
 Screen, 1-2
 Screen dump, L-13
 Search, A-18
 Sector, A-18
 Sequential, A-18

Serial, A-18
 input/output, H-5
 Service, 1-26
 SID/ZSID, J-13
 Sign, A-18
 Single-density, A-18
 Small Business Inventory, J-11
 Soft-sectored, A-18
 Software, A-19
 conversion of Z-89 to Z-100, J-1
 versions, 2-7
 Sort, A-19
 Sound tone, E-1
 Space bar, 1-10
 Speaker
 beep, E-1
 Stop bits, F-15
 Storage
 devices, 1-13
 disks, 1-13
 SuperCalc, J-1 1
 SuperSort, J-1 2
 Switch, 2-40
 DS1, G-25
 line select, 1-6, 1-7
 on/off power, 1-6
 power, 1-19
 S101, G-23
 Synchronous, A-19
 Syntax, 3-2, A-19
 System, A-19; *see* Computer

T

Tab
 column, 1-10
 key, 1-10
 Table, A-19
 Task, A-19
 Telecommunications, A-19
 Temperature range, 1-2
 Terminal, A-19 Test
 disk read, C-7
 keyboard, C-8
 memory, C-8
 power-up, C-8
 Thermal printer, A-19
 Time share, A-19
 Tone
 sound, E-1
 Track, A-20

Transmit

- 25th line, B-14
- character at cursor, B-14
- current line, B-14
- page, B-14

U

Underline

- indicator (cursor), 1-10 Utility, A-20

V

- Variable, A-20
- Ventilation, 1-3
- Verify, A-20 Video
 - composite, A-5
 - outputs, H-2
 - pages, H-2
 - RGB, A-17
- Video memory, H-1
- Volatile, A-20
- Voltage
 - input selection, 1-6

W

- When you call for help, 1-29
- Wild cards, 2-26
 - *, 2-26, 2-27
 - ?, 2-26
- Winchester, A-20
 - capacity, H-4
 - number, H-4
- Word processing, A-20
- WordMaster, J-13
- WordStar, J-12
- Working copies, 2-8
- Write. A-20

Z

- Z-BASIC, 2-1, 3-7, K-1; *see also* BASIC
 - ABS, E-5
 - AND, E-3
 - arrays, E-4
 - ASC, E-5
 - ATN, E-5
 - AUTO, E-5
 - BACK SPACE, E-2
 - BEEP, E-5
 - BLOAD, E-5
 - BSAVE, E-5
 - CALL, E-5

- CDBL, E-5
- CHAIN, E-5
- CHR\$, E-6
- CINT, E-6
- CIRCLE, E-6
- CLEAR, E-6
- CLOSE, E-6
- CLS, E-1, E-6
- COLOR, E-6
- COM, E-6
- COMMON, E-6
- CONT, E-7
- COS, E-7
- CSNG, E-7
- CSRLIN, E-7
- CTRL-A, E-1
- CTRL-B, E-1
- CTRL-C, E-1
- CTRL-E, E-1
- CTRL-F, E-1
- CTRL-G, E-1
- CTRL-H, E-1
- CTRL-I, E-1
- CTRL-J, E-1
- CTRL-L, E-1
- CTRL-M, E-1
- CTRL-N, E-1
- CTRL-RESET, E-2
- CTRL-S, E-1
- CTRL-T, E-1
- CTRL-U, E-2
- CTRL-W, E-2
- CTRL-Z, E-2, E-2
- CVD, E-7 CVI, E-7
- CVS, E-7
- D CHR, E-2
- DATA, E-7
- DATE, E-7
- DATES\$, E-7
- DEF FN, E-7
- DEF SEG, E-8
- DEF USR, E-8
- DEFDBL, E-8
- DEFINT, E-8
- DEFSNG, E-8
- DEFSTR, E-8
- DELETE, E-2, E-8
 - delete current line, E-2
- DIM, E-8
- DRAW, E-8
- EDIT, E-9

ELSE, E-9
END, E-9
EOF, E-10
EQV, E-3
ERASE, E-10
ERL, E-10
ERR, E-10
ERROR, E-10
EXP, E-10
FIELD, E-10
FILES, E-10
FIX, E-10
FOR ... TO ... NEXT, E-10
FRE, E-1 1
GET, E-1 1
GOSUB, E-11
GOTO, E-11
HEX\$, E-11
HOME, E-2
ICHR, E-2
IF...THEN...ELSE, E-11
IMP, E-3
INKEY\$, E-1 1
INP, E-11
INPUT, E-11
INPUT #, E-11
INPUT\$, E-1 1
INSTR, E-12
INT, E-12
KEY, E-12
KILL, E-12
LEFT\$, E-12
LEN, E-12
LET, E-12
LINE, E-12
LINE INPUT, E-12
LINE INPUT #, E-13
LIST, E-13
LLIST, E-13
LOAD, E-13
LOC, E-13
LOCATE, E-13
LOF, E-13
LOG, E-13
LPOS, E-13
LPRINT, E-13
LPRINT USING, E-13
LSET, E-13
MERGE, E-13
MID\$, E-14
MKD\$, E-14
MKI\$, E-1 4
MKSS\$, E-14
NAME, E-14
NEW, E-14
NOT, E-3
OCT\$, E-1 4
ON COM, E-14
ON ERROR, E-15
ON KEY, E-15
ON ...GOSUB, E-15
ON ...GOTO, E-15
OPEN, E-15
OPTION BASE, E-15
OR, E-3
OUT, E-15
PAINT, E-15
PEEK, E-16
POINT, E-16
POKE, E-16
POS, E-16
PRESET, E-16
PRINT, E-16
PRINT #, E-17
PRINT USING, E-16
PSET, E-17
PUT, E-17
PUT #, E-17
RANDOMIZE, E-18
READ, E-18
REM, E-18
RENUM, E-18
RESET, E-18
RESTORE, E-18
RESUME, E-19
RETURN, E-1, E-19
RIGHT\$, E-19
RND, E-19
RSET, E-19
RUN, E-19
SAVE, E-19
SCREEN, E-19, E-20
SGN, E-20
SIN, E-20
SPACE\$, E-20
SPC, E-20
SQR, E-20
STOP, E-20
STR\$, E-20
STRING\$, E-20
SWAP, E-20
SYSTEM, E-21
TAB, E-2, E-21

TAN, E-21
THEN..., E-21
TIME, E-21
TIMES, E-21
TROFF, E-21
TRON, E-21
USING specifiers, E-1 7
USR, E-21
VAL, E-21
VARPTR, E-22
VARPTR\$, E-22
WAIT, E-22
WEND, E-22
WHILE, E-22
WIDTH, E-22
WRITE, E-22
WRITE #, E-22
XOR, E-3
Zenith
WH-12, F-1
WH-23, F-1
WH-33, F-1
WH-34, F-1
Z-125, F-1
Z-25, F-1